

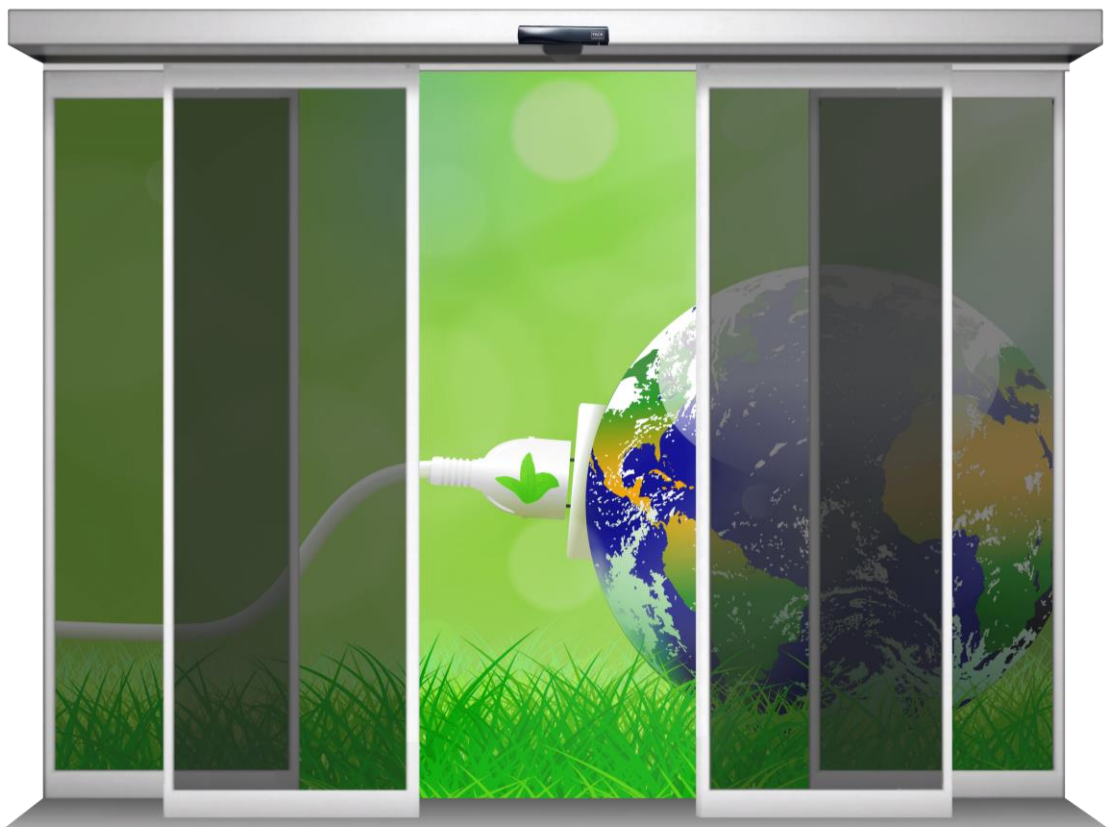

INSTALLATION AND MAINTENANCE MANUAL FOR SLIDING DOOR



SL3L LIGHT



1. INTRODUCTION

Before you begin to install or start an automatic pedestrian doors, an inspection must be carried out on site by qualified personnel, for making measurements of the compartment wall, door and drive.

This inspection is to assess the risk and to select and implement the most appropriate solutions according to the type of pedestrian traffic (intense, narrow, one-way, bi-directional, etc.), The type of users (elderly, disabled, children, etc.), in the presence of potential hazards or local circumstances.

To assist installers in applying the requirements of European Standard EN 16005 concerning the safe use of automatic pedestrian doors, we recommend consulting the guides E.D.S.F. (European Door and Shutter Federation) available on www.edsf.com.

1.1 GENERAL SAFETY INSTRUCTION

This installation manual is intended for professionally competent personnel only. Before installing the product, carefully read the instructions.

Bad installation could be hazardous. The packaging materials (plastic, polystyrene, etc.) should not be discarded in the environment or left within reach of children, as these are a potential source of hazard.

Before installing the product, make sure it is in perfect condition. Do not install the product in an explosive environment and atmosphere: gas or inflammable fumes are a serious hazard risk.

Before installing the automations, make all structural changes relating to safety clearances and protection or segregation of all areas where there is risk of being crushed, cut or dragged, and danger areas in general.

Make sure the existing structure is up to standard in terms of strength and stability. FACE is not responsible for failure to use Good Working Methods in building the frames to be motorised or for any deformation occurring during use.

The safety devices (safety sensor, photocells, etc.) must be installed taking into account: applicable laws and directives, Good Working Methods, installation premises, system operating logic and the forces developed by the motorised door.

Apply hazard area notices required by applicable regulations.

The emission sound pressure level of the door is $LpA \leq 70dB(A)$.

Each installation must clearly show the identification details of the automatic pedestrian door.

The product, in its original packaging supplied by the manufacturer, must only be transported in a closed environment (railway carriage, containers, closed vehicles).

If the product malfunctions, stop using it and contact an authorised support centre.

The manufacture date is provided in the production batch printed on the product label. If necessary, contact us at www.facespa.it.

The general conditions of sale are given in the official FACE price lists.

1.2 CE MARKING AND EUROPEAN DIRECTIVES



Automations for sliding pedestrian, are designed and manufactured in compliance with the safety requirements of the European standard EN 16005 and are CE-marked in accordance with the Electromagnetic Compatibility Directive (2014/30/UE).

The automation also include a Declaration of Incorporation according to the Machinery Directive (2006/42/EC).

Pursuant to Machinery Directive (2006/42/CE) the installer who motorises a door or gate has the same obligations as the manufacturer of machinery and as such must:

- prepare the technical file which must contain the documents indicated in Annex V of the Machinery Directive; (The technical file must be kept and placed at the disposal of competent national authorities for at least ten years from the date of manufacture of the pedestrian door);
- draft the EC declaration of conformity in accordance with Annex II-A of the Machinery Directive and deliver it to the customer;
- affix the CE marking on the power operated door in accordance with point 1.7.3 of Annex I of the Machinery.

All data and information contained in this manual have been drawn up and checked with the greatest care. However FACE cannot take any responsibility for eventual errors, omissions or inaccuracies due to technical or illustrative purposes.

FACE reserves the right to make changes and improvements to their products. For this reason, the illustrations and the information appearing in this document are not definitive.

This edition of the manual cancels and replaces all previous versions. In case of modification will be issued a new edition.



DECLARATION OF INCORPORATION

Machines Directive 2006/42/EC, Annex II-B



FACE S.r.l.

Viale delle Industrie, 74 - 31030 Dosson di Casier (TV) - ITALY

Declares that:

The Product automations for power operated pedestrian sliding door type: **SL3L**

Has been built for installation on pedestrian door and constitutes a machine in accordance with Directive 2006/42/EC. The manufacturer of the power operated pedestrian door must declare its conformity in accordance with Directive 2006/42/EC (Annex II-A) prior to starting-up the machine.

It complies with the applicable essential safety requirements specified in Annex I, chapter 1 of Directive 2006/42/EC:

1.1.2, 1.1.3, 1.2, 1.3.1, 1.3.2, 1.3.4, 1.3.7, 1.3.8, 1.4, 1.5.1, 1.5.2, 1.5.10, 1.5.11, 1.5.14, 1.6.1, 1.6.3, 1.7

It complies with the Electromagnetic Compatibility Directive 2014/30/UE.

It complies with following harmonized standards:

EN 16005 Power operated pedestrian doorsets - Safety in use - Requirements and test methods

EN 60335-2-103 Household and similar electrical appliances - Safety - Part 2: Particular requirements for drives for gates, doors and windows

The technical documentation complies with Annex VII-B to Directive 2006/42/EC.

The technical documentation is managed by: Ferdinando Menuzzo with registered offices in Viale delle Industrie, 74 - 31030 Dosson di Casier (TV) - ITALY

A copy of the technical documentation shall be supplied to the competent national authorities following duly motivated request.

Place and date:

Dosson di Casier, 2022-09-01

Paolo Bacchin
Managing Director

A handwritten signature in blue ink, appearing to read "Paolo Bacchin", written over the printed name and title.

FACE S.r.l.

Viale delle Industrie, 74

31030 – Dosson di Casier (TV) Italy

Phone +39 0422 492730 Fax +39 0422 380414

www.facespa.it





Iscritta al Reg. Imp. di Treviso al n. 04552520266

C.F.-P.I. 04552520266

Capitale Sociale € 100.000,00 i.v.

R.E.A. di Treviso n. 359250

2. TECHNICAL DATA

Features	SL3L
Automation type	LIGHT
Max product dimensions: Height x Depth x Maximum length	100 x 148 x 6600 mm
Maximum weight of door 1 leaf: Maximum weight of door 2 leaves:	1 x 70 kg (100%) 2 x 50 kg (100%) / 2 x 60 kg (S3 = 80%)
Maximum opening and closing speed: Sliding door 1 door Sliding door 2 doors	0,8 m/s 1,6 m/s
Duty class Intermittent operation	Continuous operation 100% (2 x 50 kg) / S3 = 80% (2 x 60 kg)
Power supply Rated power Stand-by	100–240 Vac 50/60 Hz 60 W 8 W
Rated load	80 N
Protection Rating	IP 20
Operating temperature Storage temperature (*)	 -15 °C  +50 °C  -20 °C  +70 °C
Average life (**)	3.000.000 cycles
Power output for accessories	12 Vdc (1 A max)
Memory for settings and saving	USB / micro SD
Electronic function selector	FSD5, FSD6
Locking device	SL3LD, SL3SB1
Battery power device	SL3BD1
Fixing device for sensors	SL3FS

(*) Before installing the product, keep it at room temperature where it has previously been stored or transported at a very high or very low temperature.

(**) The average product life specified should be understood purely as an indicative estimate. It applies to normal usage conditions and where the product has been installed and maintained in compliance with the instructions provided in the technical manual. The average product life is also affected, including significantly, by other variables such as, but not limited to, climatic and environmental conditions. The average product life should not be confused with the product warranty.

N.B. The technical data above refer to average conditions of use and cannot be certain in each case. Each automatic entrance variables such as: friction, balancing and environmental conditions may substantially change both the duration and the quality of the operation of the automatic entrance or some of its components, including the automation. The installer must adopt adequate safety coefficients for each particular installation.

3. STANDARD INSTALLATION

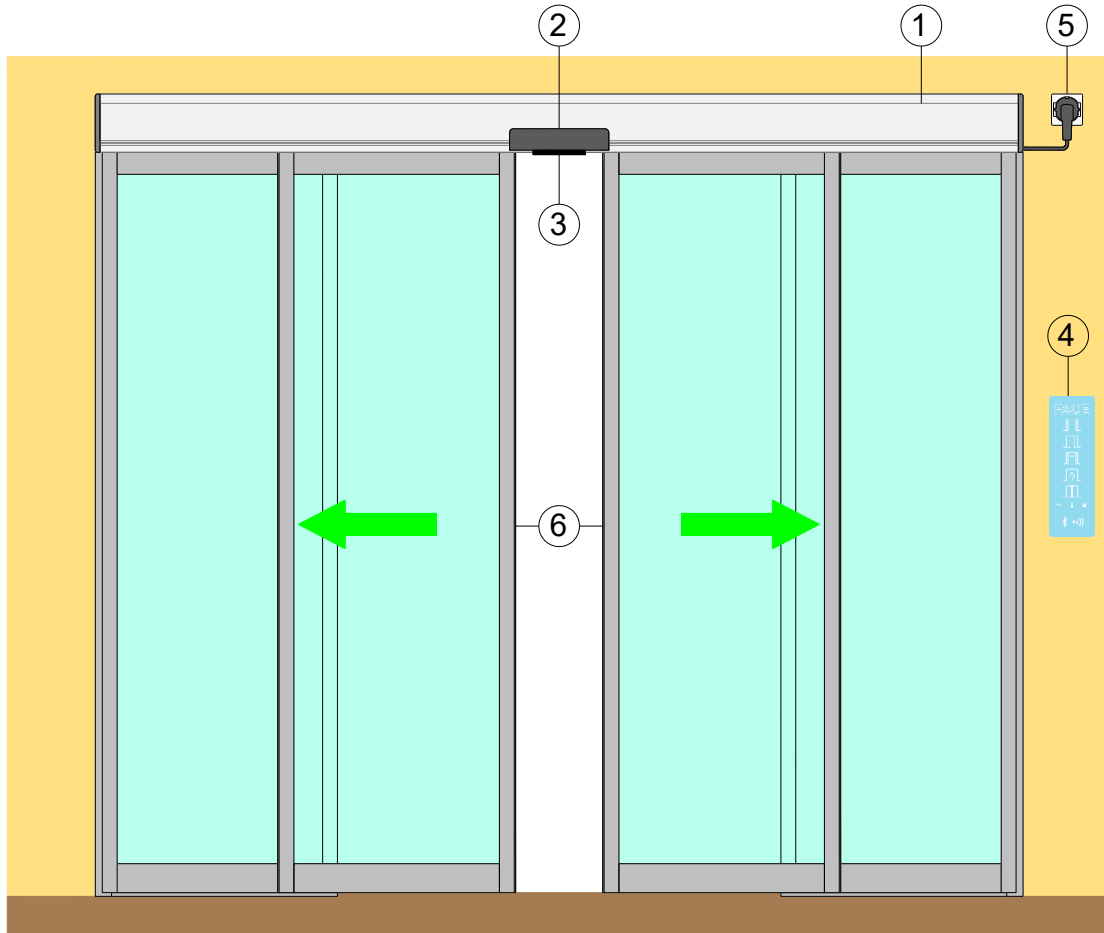

Rif.	Code	Description
1	SL3L220 – SL3L266	Automation for sliding doors
2	OSD1, OSD3, OSD4, OSD5, OSD6, OSD8	Opening and safety sensor (N.B. To ensure the safety of the doorway, are needed 2 sensors, one on each side)
3	SL3FS	Device for fixing sensors
4	FSD5, FSD6	Electronic function selector
-	SL3BD1	Battery power device
-	SL3LD	Bistable locking device
5	-	Power cable for connection of the automation
6	SF30	Sliding door profile system

Note: Components and codes are those most commonly used in systems for automatic sliding doors. The full range of equipment and accessories is also available in the sales list.

The given operating and performance features can only be guaranteed with use of FACE accessories and safety devices.

4. SIZING FOR SLIDING AUTOMATION

The correct sizing of an automatic sliding door depends on the size of the compartment wall and the present encumbrance.

The following tables provide the installation measurements refer to the codes list (considering perimeter profiles and overlaps average), are also indicated the applied formulas to obtain the installation measurements based on the actual dimensions of the wall and frame systems.

To facilitate the calculations and the choice for the ordination of automatic sliding doors, FACE has developed SDC computer program (Sliding Door Configurator), available at www.facespa.it in Download area.

4.1 SIZING FOR 2 SLIDING DOORS

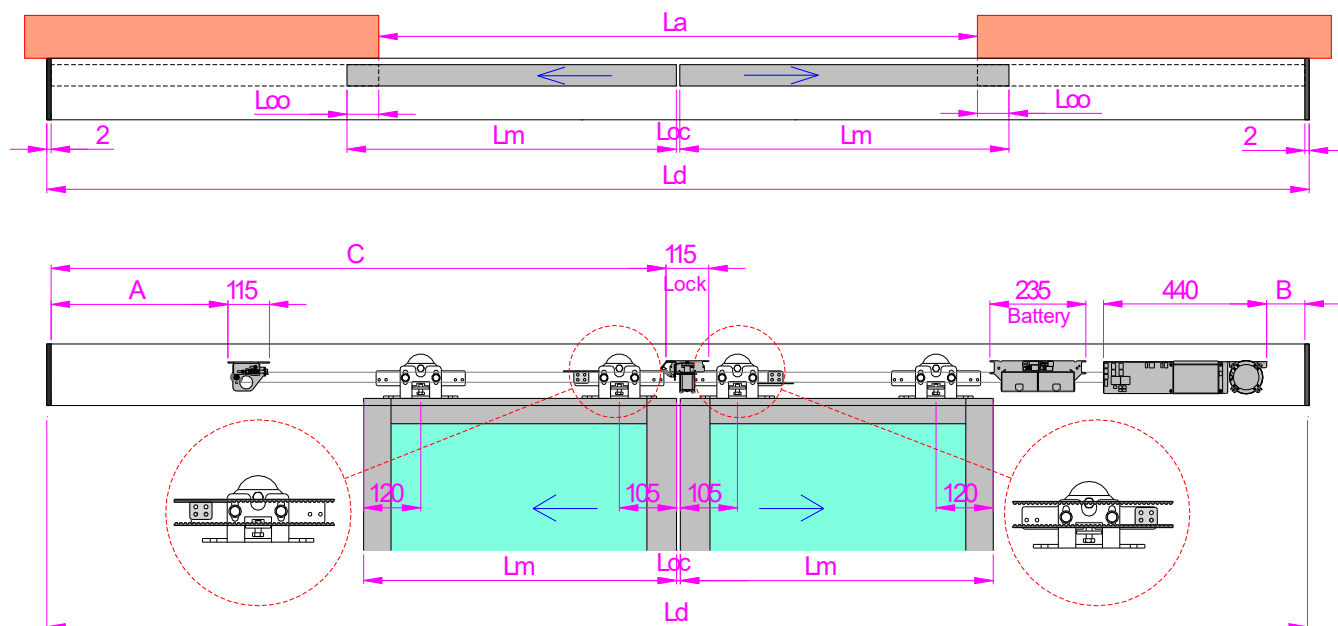

$L_d = L_a + 2L_m + 4 \text{ automation length}$

$L_a = \text{width of the doorway}$

$L_m = (L_a - L_{oc} + 2L_{oo}) / 2$ leaf width

L_{oo} = overlapping open side door (depending on the type of used frame system)

L_{oc} = overlapping closes side door (depending on the type of used frame system)

Ld	La	Lm	A	B	C	Belt
2.000 mm	948 mm	2 x 524 mm	191 mm	201 mm	940 mm	3,2 m
2.200 mm	1.048 mm	2 x 574 mm	241 mm	251 mm	1.040 mm	3,4 m
2.600 mm	1.248 mm	2 x 674 mm	341 mm	351 mm	1.240 mm	3,8 m
3.000 mm	1.448 mm	2 x 774 mm	441 mm	451 mm	1.440 mm	4,2 m
3.300 mm	1.598 mm	2 x 849 mm	516 mm	526 mm	1.590 mm	4,5 m
3.600 mm	1.748 mm	2 x 924 mm	591 mm	601 mm	1.740 mm	4,8 m
4.000 mm	1.948 mm	2 x 1.024 mm	691 mm	701 mm	1.940 mm	5,2 m
4.400 mm	2.148 mm	2 x 1.124 mm	791 mm	801 mm	2.140 mm	5,6 m
5.000 mm	2.448 mm	2 x 1.274 mm	941 mm	951 mm	2.440 mm	6,2 m
6.600 mm	3.248 mm	2 x 1.674 mm	1.341 mm	1.351 mm	3.240 mm	7,8 m

(Note: values shown are calculated considering $L_{oo} = 50 \text{ mm}$ e $L_{oc} = 0 \text{ mm}$)

4.2 SIZING FOR 1 SLIDING DOOR OPENING TO THE RIGHT

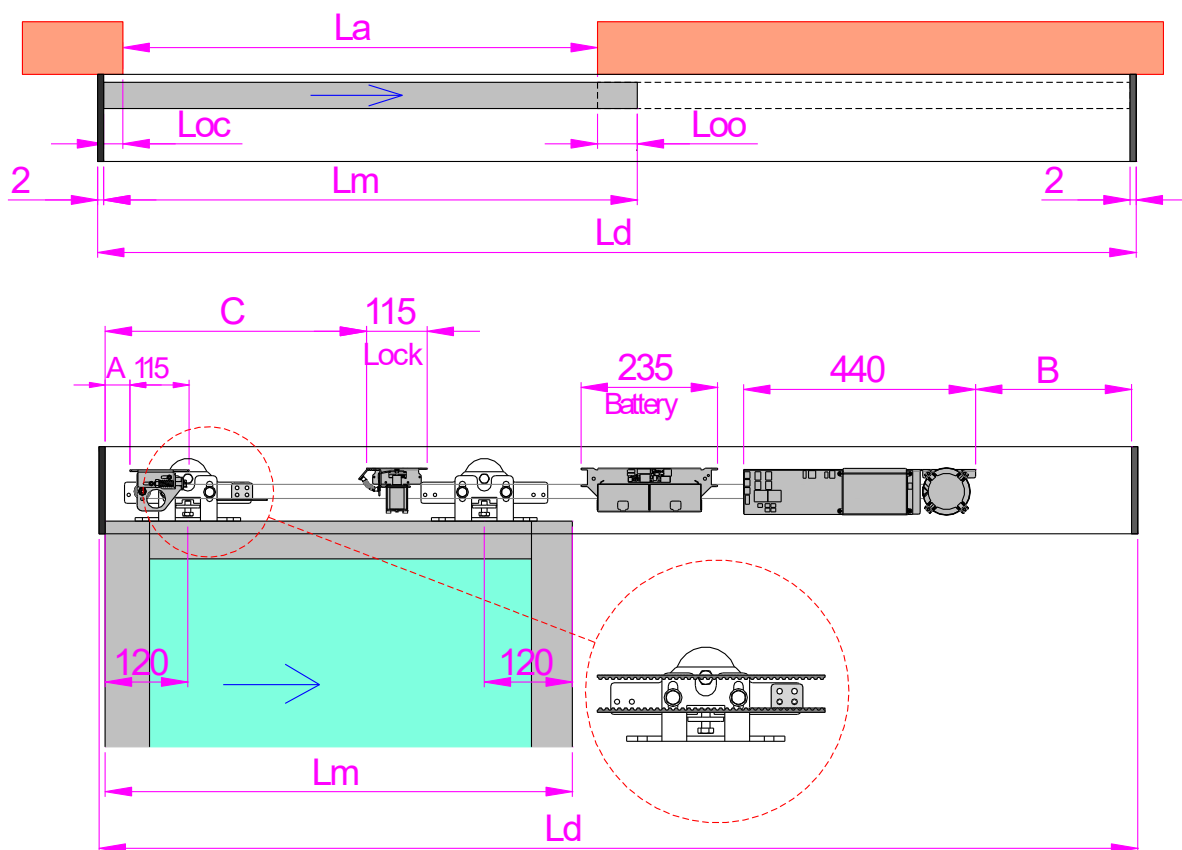

$L_d = L_a + L_m + L_{oc} + 4$ automation length

L_a = width of the doorway

$L_m = L_a + L_{oc} + L_{oo}$ leaf width

L_{oo} = overlapping open side door (depending on the type of used frame system)

L_{oc} = overlapping closes side door (depending on the type of used frame system)

Ld	La	Lm	A	B	C	Belt
2.000 mm	923 mm	1.023 mm	46 mm	685 mm	735 mm	2,5 m
2.200 mm	1.023 mm	1.123 mm	46 mm	785 mm	835 mm	2,7 m
2.600 mm	1.223 mm	1.323 mm	46 mm	985 mm	1.035 mm	3,1 m
3.000 mm	1.423 mm	1.523 mm	46 mm	1.185 mm	1.235 mm	3,5 m
3.300 mm	1.573 mm	1.673 mm	46 mm	1.335 mm	1.385 mm	3,8 m
3.600 mm	1.723 mm	1.823 mm	46 mm	1.485 mm	1.535 mm	4,1 m
4.000 mm	1.923 mm	2.023 mm	46 mm	1.685 mm	1.735 mm	4,5 m
4.400 mm	2.123 mm	2.223 mm	46 mm	1.885 mm	1.935 mm	4,9 m
5.000 mm	2.423 mm	2.523 mm	46 mm	2.185 mm	2.235 mm	5,5 m
6.600 mm	3.223 mm	3.323 mm	46 mm	2.985 mm	3.035 mm	7,1 m

(Note: values shown are calculated considering $L_{oo} = 50$ mm and $L_{oc} = 50$ mm)

4.3 SIZING FOR 1 SLIDING DOOR OPENING TO THE LEFT

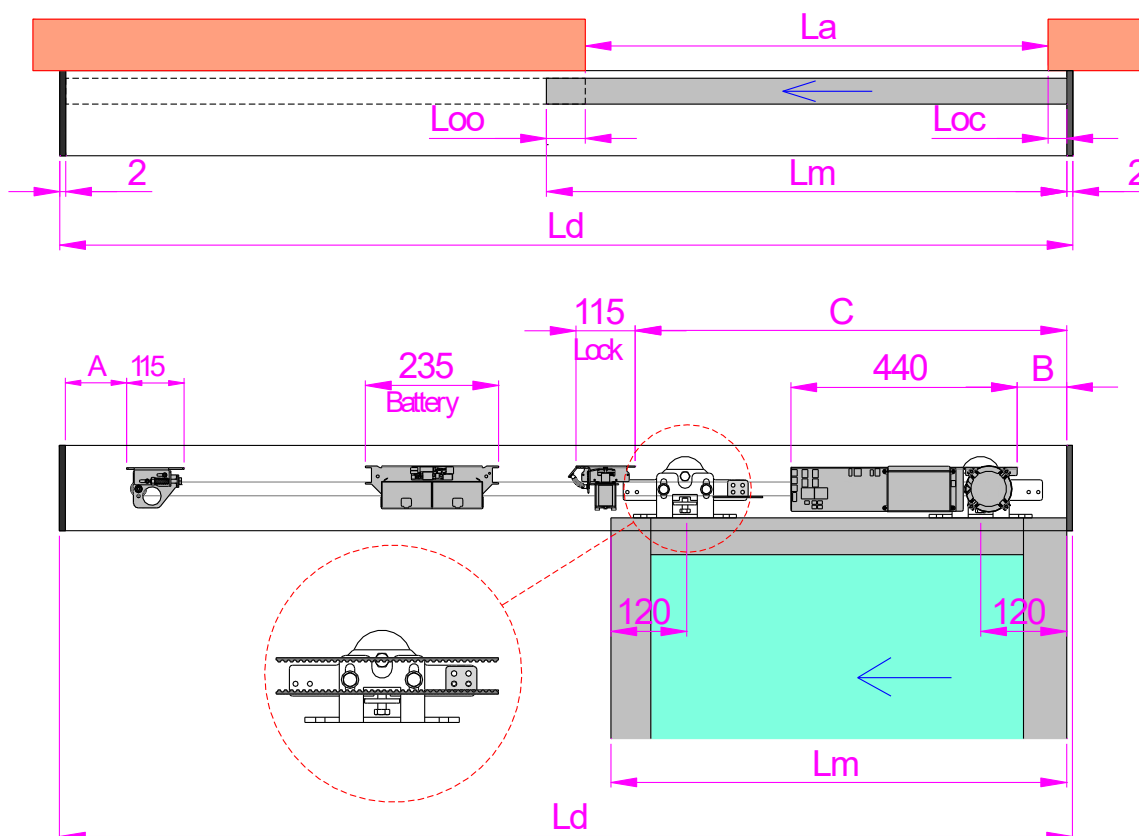

$L_d = L_a + L_m + L_{oc} + 4$ automation length

L_a = width of the doorway

$L_m = L_a + L_{oc} + L_{oo}$ leaf width

L_{oo} = overlapping open side door (depending on the type of used frame system)

L_{oc} = overlapping closes side door (depending on the type of used frame system)

L_d	L_a	L_m	A	B	C	Belt
2.000 mm	923 mm	1.023 mm	46 mm	515 mm	955 mm	2,9 m
2.200 mm	1.023 mm	1.123 mm	46 mm	615 mm	1.055 mm	3,1 m
2.600 mm	1.223 mm	1.323 mm	46 mm	815 mm	1.255 mm	3,5 m
3.000 mm	1.423 mm	1.523 mm	46 mm	1.015 mm	1.455 mm	3,9 m
3.300 mm	1.573 mm	1.673 mm	46 mm	1.165 mm	1.605 mm	4,2 m
3.600 mm	1.723 mm	1.823 mm	46 mm	1.315 mm	1.755 mm	4,5 m
4.000 mm	1.923 mm	2.023 mm	46 mm	1.515 mm	1.955 mm	4,9 m
4.400 mm	2.123 mm	2.223 mm	46 mm	1.715 mm	2.155 mm	5,3 m
5.000 mm	2.423 mm	2.523 mm	46 mm	2.015 mm	2.455 mm	5,9 m
6.600 mm	3.223 mm	3.323 mm	46 mm	2.815 mm	3.255 mm	7,5 m

(Note: values shown are calculated considering $L_{oo} = 50$ mm and $L_{oc} = 50$ mm)

4.4 PROFILES AND GASKET CUTTING MEASURE

All the aluminium profiles and gaskets needed for the realization of the automations must be cut 4 mm shorter than the maximum length of the automation ($L_d - 4$), also including the plastic end caps.

Ref.	Code	Description	SL3
701	K701G66	Drive unit profile raw aluminum 6620 mm	
104	K104A66	Rail profile anodized aluminum 6620 mm	
702	K702G66	Cover profile raw aluminum 6620 mm	
	K702A66	Cover profile anodized aluminum 6620 mm	
107D	K107D	Cover gasket 40 m	

4.5 VERTICAL DOOR DIMENSION

The automations are compatible with the majority of frame in trade.

The formulas are for the calculation of the vertical measure fastening automations (H_d), and for the calculation of the height of sliding door (H_m).

Note: make sure that there is at least 20 mm above the automation, to allow the opening of the cover.

You can make sliding leaves by means of aluminum profiles SF30 series, as indicated in the figure.

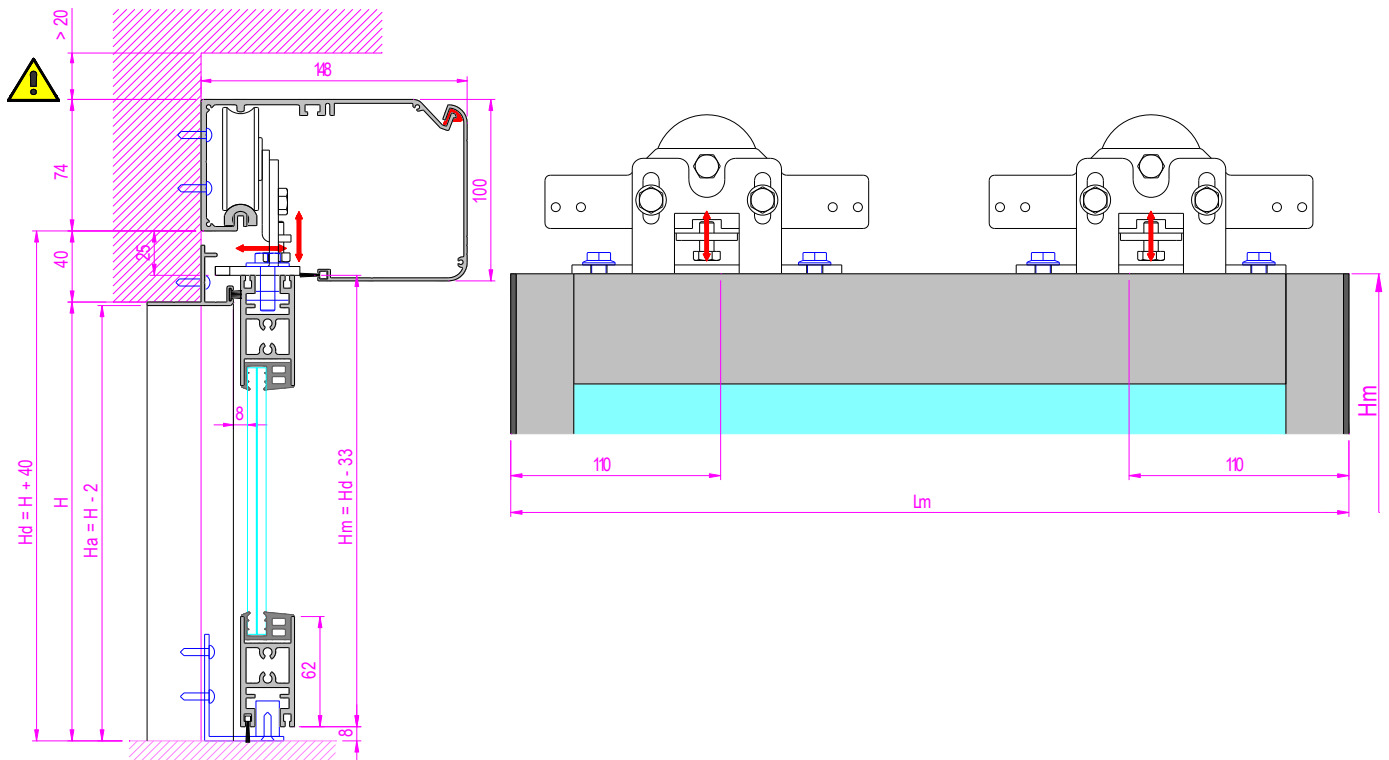

To facilitate the horizontal adjustment of the leaves you can use the fixing door profile and the floor guide kit, as indicated in the figure.

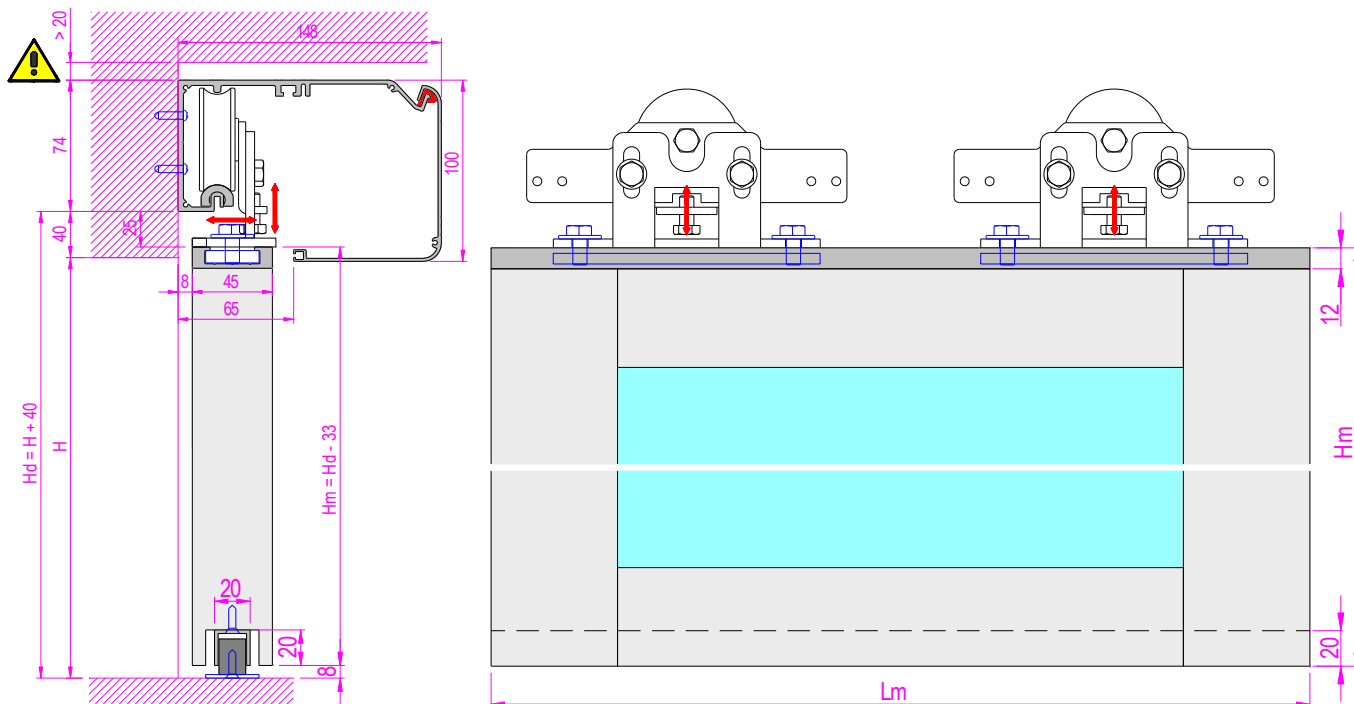

To make doors with glass doors, you can use the fixing profile for glass door, as indicated in the figure.

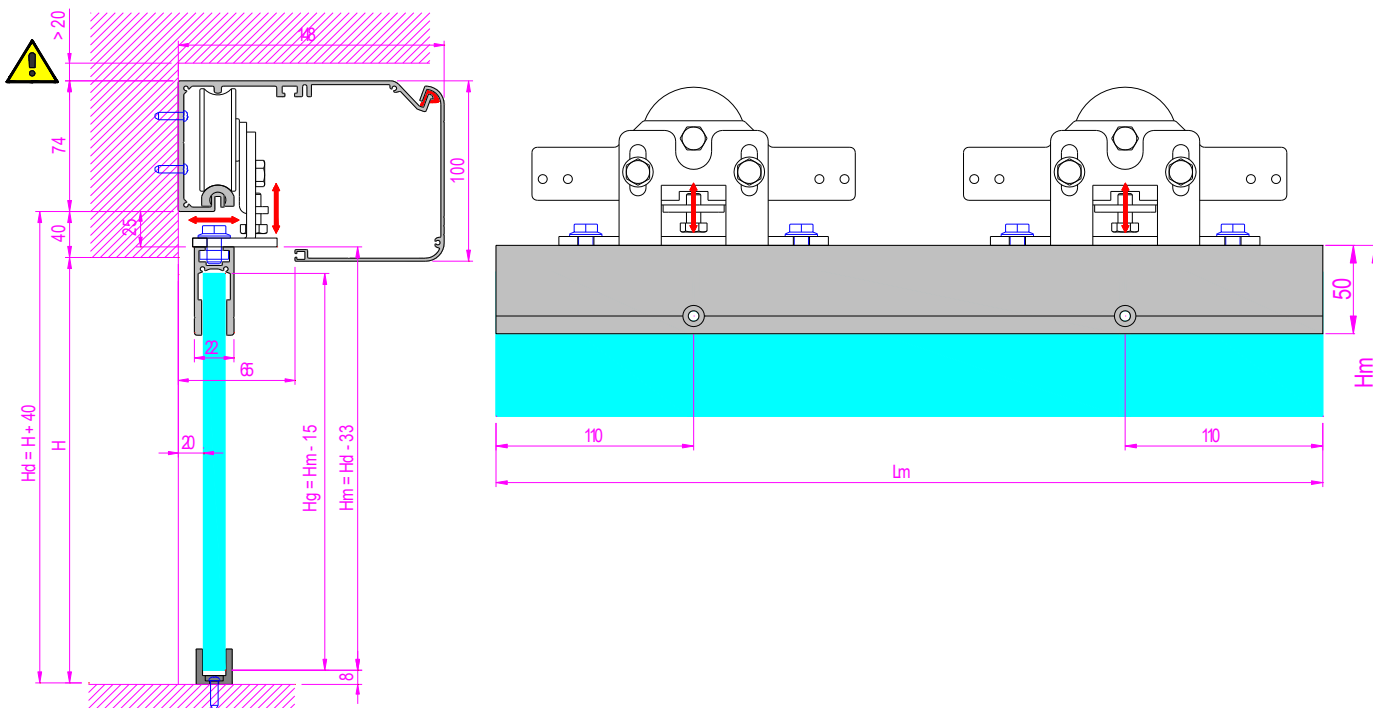

5. ASSEMBLY PROCEDURE OF THE AUTOMATION

The automations should be assembled by qualified personnel, and can be done at the factory or directly at the place of installation of the door. After size cutting all aluminium profiles and gaskets (as indicated in the chapter 4), we proceed with the automation and internal components assembly.

5.1 ASSEMBLY OF THE AUTOMATION

- Insert the rail profile in the drive unit profile.
- Insert the cover gasket on the drive unit profile.
- Insert the carriages by side on the drive unit profile. The carriages should be positioned as shown in Chapter 4.
- Insert the two brackets mechanical stop near the end caps, and secure with the screws. In the case of 2-leaves automation, add a mechanical stop bracket to the center.
- Insert the M5x10 screws needed for fix the internal components of the automation: n.2 for the transmission unit, n.2 for the locking device, n.2 for the batteries, n.2 for the electronic control, n.2 for the brushless motor, n.2 for the device for fixing sensor.
- Fix the right and the left end caps on the drive unit profile, and secure them with the screws [a].
- Fix the brushless motor and the electronic control on the drive unit profile, placed at a maximum B (as shown in Chapter 4), and secure it with the screws (Note: if there is space, it's better to reduce measure B few centimetres).
- Fix the transmission unit on the drive unit profile, place it to maximum A (as described in Chapter 4), and secure it with the screws (Note: if there is space, it's better to reduce measure A few centimetres).
- Insert the belt in the pulley of brushless motor, slide it and pass it around the transmission unit and fix to carriage with the proper springs (see the belt attack position, as shown in Chapter 4).
- Fix the cable clamps [b] on the drive unit profile, and secure it with the screws [c]. The cable clamps should be positioned along the path of the electrical cables in order to prevent it from interfering with the running of the carriages.

5.2 AUTOMATION CLOSING

- Screw the side screws [d] on the cover profile (as shown in figure).
- Hang the cover profile to the drive unit profile, and secure it with the side screws [d].

Note: if there is no space on the side, make two holes on the cover profile (as shown in the figure) and secure it to the end caps using the supplied screws [e].

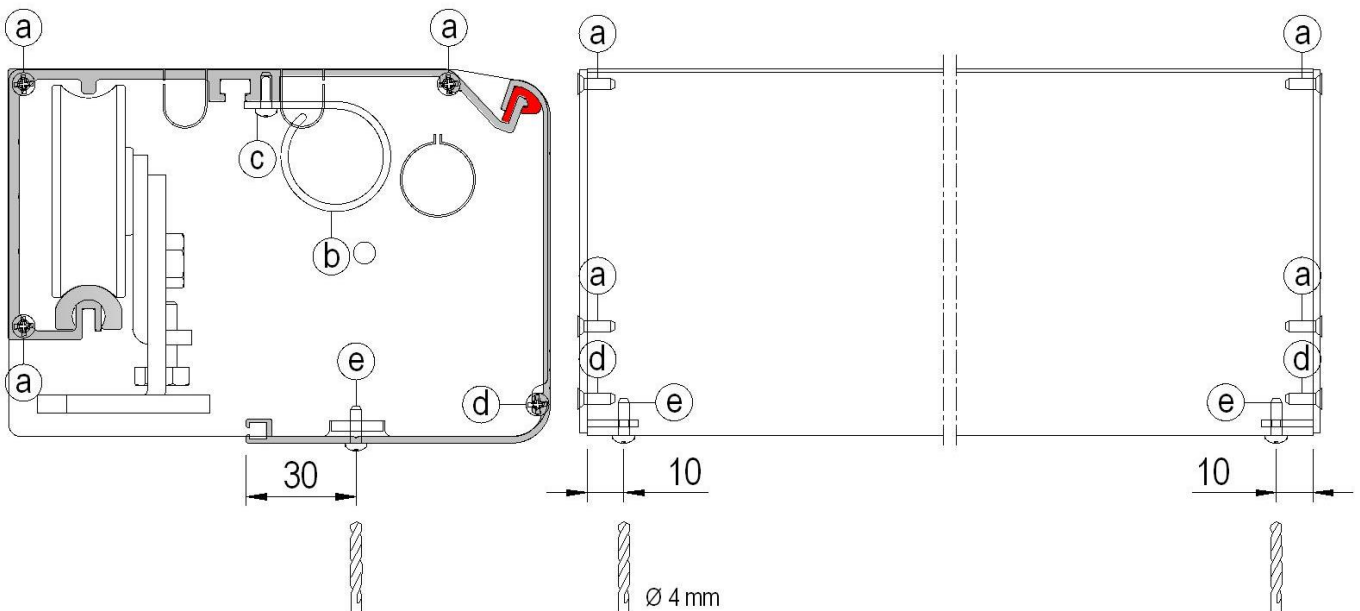

6. AUTOMATION AND SLIDING DOORS INSTALLATION

The installation of an automatic sliding door, carried out by qualified personnel, can take place only after the on-site inspection (described in section 1), and after the design and construction of the system frame and automation (described in section 4).

6.1 Fix the drive unit profile to the wall in accordance with the vertical measurements in chapter 4.5.

Fixing of the drive unit profile to the wall must be safe and suitable for the weight of the doors. Distribute the fixing points every 500 to 800 mm along the present lines on the aluminium profile, using suitable plugs and screws, not supplied by us.

Note: the wall must be straight and smooth, otherwise you have to prepare adequate thickness or iron plates on which to secure the drive unit profile, to allow for proper leveling.

6.2 Must be prepared and executed the channel and the holes for the passage of the power cord and cables for connecting the control and safety devices (sensors, function selector, buttons, etc.).

6.3 Adjust the tension of the belt with the transmission unit as shown in the figure:

- Manually push to left the transmission unit, so as to tension the belt, and attach it to the drive unit profile by screws,
- Loosen the screw [a],
- Tighten the screw [b] and completely compress the spring until about 17 mm (always check manually, the belt tension is not too tight or too loose),
- Lock the adjustment of the belt tension by tightening the screw [a].

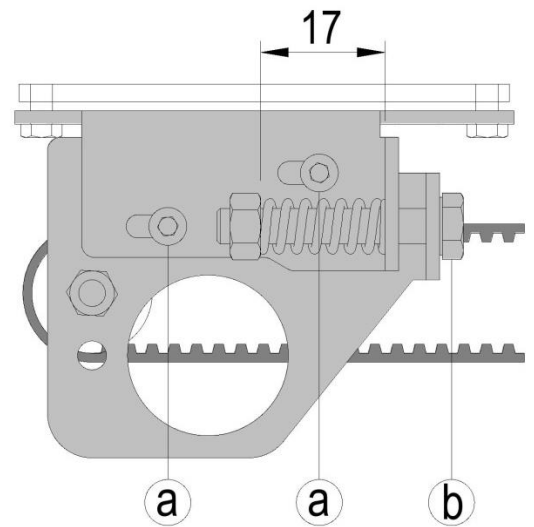
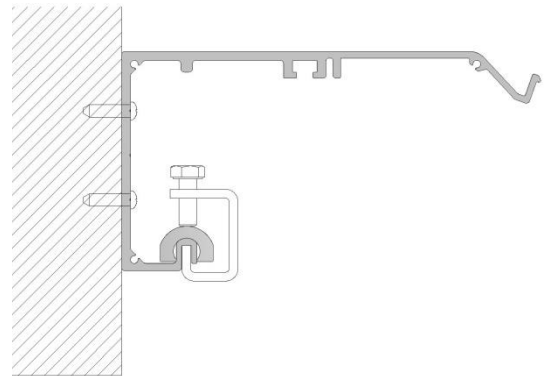

6.4 Passage of electrical cables automation.

In the upper part of the end caps is prepared the area pre-drilled for the passage of electric cables. The route of the cables inside the automation is supported and guided by the cable clamps, as indicated in Section 5.

6.5 Secure the sliding doors to the carriages by 8MA screws, as shown in Chapter 4.

Take the doors in the closed position and make adjustments in height and depth.

Manually move the leaves throughout all the way and make sure it moves freely and without friction.

Make sure that the bottom of the doors is properly guided by the floor runner. Adjust the position of the brackets with a mechanical stop to limit the travel of the doors in the desired locations.

7. ELECTRICAL CONNECTIONS

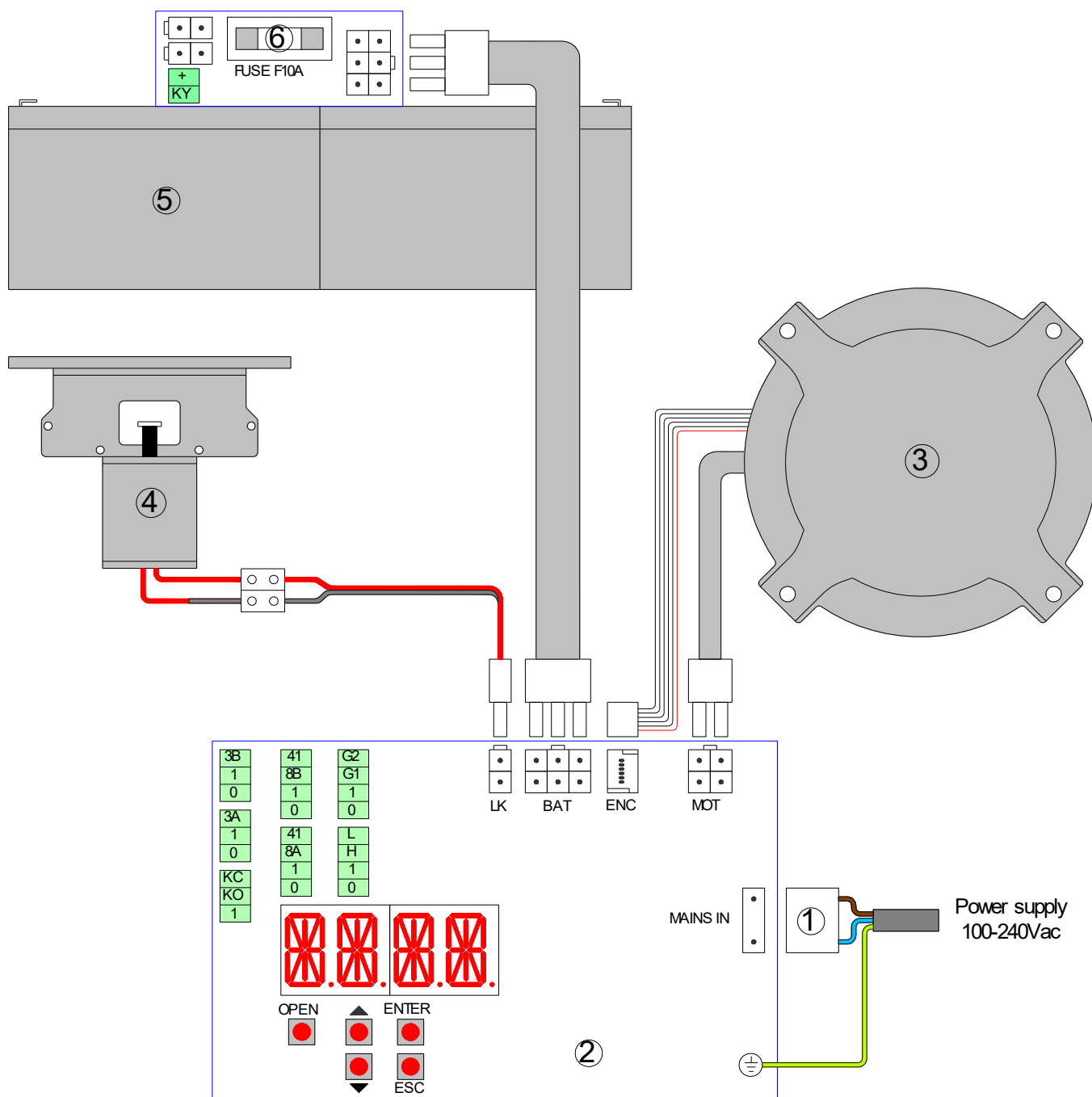

Rif.	Code	Terminals	Description
1	2329	MAINS IN	Cable for connection to the power supply.
2	5CB08		Electronic control
3	5B9015L	MOT	Brushless motor
		ENC	Angular sensor
4	SL3LD	LK	Locking device
5	SL3BD1	BAT	Battery power device (SL5BD2 code for Emergency exit)
6		FUSE	Battery fuse 5x20 - F10A

7.1 GENERAL SAFETY ELECTRICAL PRECAUTIONS

Installation, electrical connections and adjustments must be completed in conformity with Good Working Methods and with regulations in force.

Before making power connections, check that the rating corresponds to that of the mains supply. A multipolar disconnection switch with a contact opening gap of at least 3 mm must be included in the mains supply. This switch must be protected from unauthorized activations.

Check that upstream of the electrical installation an adequate residual current circuit breaker and an overcurrent cut out are fitted.

Connect the automation to an effective earthing system carried out as indicated by current safety regulations.

During installation, maintenance and repair operations, cut off the power supply before opening the cover to access the electrical parts. To handle electronic parts, wear earthed antistatic conductive bracelets.

FACE declines all responsibility in the event of components which are not compatible with the safe and correct operation of the product.

For repairs or replacements of products only original spare parts must be used.

7.2 POWER SUPPLY ELECTRICAL CONNECTION



Use the supplied cable for connection to electricity.

The power cable can be connected to an electric plug (not supplied by us), arranged near the end cap of the automation.

Drill a hole in the end cap area prepared, route the power cord and secure it by a PG11 cable gland, not supplied by us.

In case there isn't a socket near the automation, to perform the connection to the power supply in the following manner: drill the aluminum profile in the upper part or in the rear wall fixing, protect the passage of the power cord through membrane grommets or cable glands (not supplied by us) to eliminate sharp edges that might damage the power cable, and connect the cable to the power supply.

The connection to the mains supply in the outer portion automation, should be an independent channel, separated from the connections to control and safety devices.

7.3 TERMINAL OF ELECTRONIC CONTROL

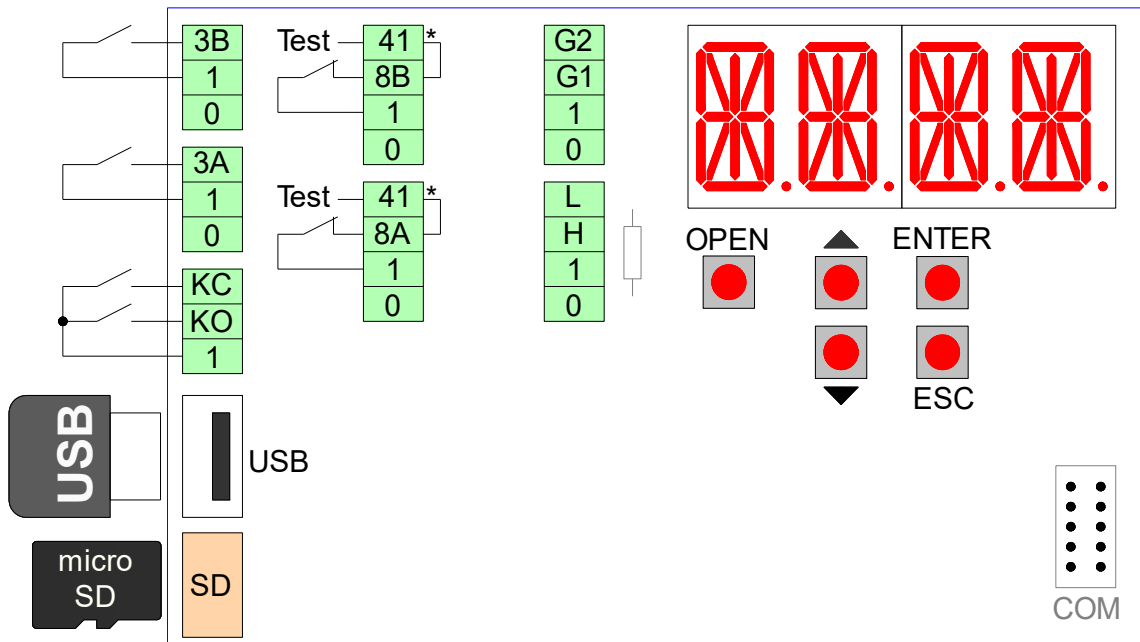

Note: The terminals with the same number are equivalent.

The electronic control comes with the jumpers on the terminals with an asterisk [*]. When connecting safety devices remove the jumpers of the corresponding terminals.

Terminals	Description
0 – 1	Output 12 Vdc for external powering accessories. The maximum absorption of 1 A corresponds to the sum of all the terminals 1 (+12V).
1 – 3A	Contact N.O. opening A side (interior side).
1 – 3B	Contact N.O. opening B side (outer side).
1 – KO	Contact N.O. aperture priority, connect to devices accessible only by authorized personnel with keys or codes.
1 – KC	Contact N.O. closing priority, connect to devices accessible only by authorized personnel with keys or codes.
1 – 8A	Safety contact N.C. on doorway side A (interior side). When the door is closing, the opening of the contact causes the reversal of the movement. Note: connect safety devices with test (see terminal 41), and remove the jumper 41 - 8A.
1 – 8B	Safety contact N.C. on doorway side B (outer side). When the door is closing, the opening of the contact causes the reversal of the movement. Note: connect safety devices with test (see terminal 41), and remove the jumper 41 - 8A.
41	Test output (+12 V). Connect the safety devices with test (in accordance with EN 16005), as indicated in the following chapters. Note: in case of devices without test, connect the N.C. contact to terminals 41 - 8A or 41 - 8B.
1 – G1	Input terminal provided for general use. Using the ADV > STG1 menu you can choose a specific function to the G1 terminal.
1 – G2	Input terminal provided for general use.
0 – G2	Output terminal (12 Vdc, 30 mA max) provided for general use. Using the ADV > STG2 menu you can choose a specific function to the G2 terminal.
0 – 1 – H – L	Bus connection to the function selector.
USB	Standard connection for USB memory cards. Allows saving the door settings and loading the firmware updates.
SD	Standard connection for micro SD memory cards. Allows saving the door settings and loading the firmware updates.
COM	Connection for remote communication

Buttons	Description
OPEN	Open the door.
↑	Scroll the menu and increase of selected values.
↓	Scroll the menu and reduction of selected values.
ENTER	Button to select the menu and save the selected data.
ESC	Exit the menu.

7.4 ELECTRICAL CONNECTION OF FUNCTION SELECTOR









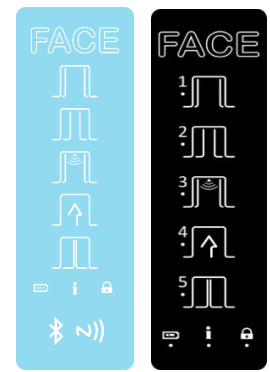

Connect the 0-1-H-L terminals of the function selector, by cable (not supplied by us), to the 0-1-H-L terminals of the electronic control.

Note: for lengths over 10 m, use a cable with 2 twisted-pairs.

ATTENTION: the function selector must be used by authorized personnel only; if it is installed in a place accessible to the public, the function selector must be protected by a proximity badge (13.56MHz ISO15693 and ISO14443 Mifare) or by a numeric code (max 40 badges and codes).

The function selector allows the following settings.



Symbol	Description
	<p>OPEN DOOR When selected, the symbol lights up, the door is permanently open. Note: the leaves can still be handled manually.</p> <p>LOW SPEED OPERATION Select the symbol for 5 seconds (double beep), the AUTOMATIC symbol flashes and the door works without safety sensors with reduced closing speed. Note: this mode must be used temporarily in the event of a malfunction of the safety sensors.</p>
	<p>AUTOMATIC PARTIAL OPERATION When selected, the symbol lights up and automatic operation of the door is with a partial opening of the leaves.</p>
	<p>AUTOMATIC BI-DIRECTIONAL OPERATION When selected, the symbol lights up, the door works automatic in bidirectional mode.</p> <p>RESET Select the symbol for 5 seconds, the automation performs the self-test and the automatic learning.</p>
	<p>AUTOMATIC ONE-WAY OPERATION When selected, the symbol lights up and automatic operation of the door is in one-way mode.</p>
	<p>CLOSED DOOR When selected, the door is permanently closed. If the locking device is present, the door is closed and locked. Note: using the menu SEL > DLAY you can adjust the delay time to close the door.</p> <p>CLOSING PRIORITY Select the symbol for 3 seconds, the automation closes slowly. Note: if present, the safety sensors are disabled.</p>
	<p>PROTECTED FUNCTION SELECTOR The symbol lights up if the function selector is protected. To activate the temporary operation of the function selector is necessary to approach the badge to the NFC symbol, or enter the code, or select for 3 seconds the logo.</p>
	<p>ACTIVATION OF FUNCTION SELECTOR BY LOGO (SEL>SECL=LOGO) Select the logo for 3 seconds (the lock symbol light off), the function selector is activated for 10 seconds. Expired the time the function selector switches off (the lock symbol lights up). Note: the function selector logo flashes when the CAN bus communication is not working (H-L terminals).</p>
	<p>ACTIVATION OF FUNCTION SELECTOR BY BADGE (SEL>SECL=TAG) Approach the badge to the NFC symbol (the lock symbol light off), the function selector is activated for 10 seconds. Expired the time the function selector switches off (the lock symbol lights up).</p>
1 2 3 4 5	<p>ACTIVATION OF FUNCTION SELECTOR BY NUMERIC CODE (SEL>SECL=TAG) Press the logo, enter the code (maximum 5 numbers), press the logo for confirmation, (the lock symbol light off), the function selector is activated for 10 seconds. Expired the time the function selector switches off (the lock symbol lights up).</p>
	<p>BATTERY SIGNAL Battery symbol off = the door is operating with the mains supply Battery symbol on = the door is operating with battery power Battery symbol flashing = the battery is low or disconnected</p>
	<p>INFORMATION SIGNAL Information symbol on = it is necessary to perform the ordinary maintenance of the door. Information symbol flashing = shows the presence of alarms: - 1 flash = failure of electronic control or locking device; - 2 flashes = mechanical failure; - 3 flashes = failure of sensor safety test; - 4 flashes = motor overtemperature.</p>

7.5 ELECTRICAL CONNECTION OF OPENING AND SAFETY SENSOR

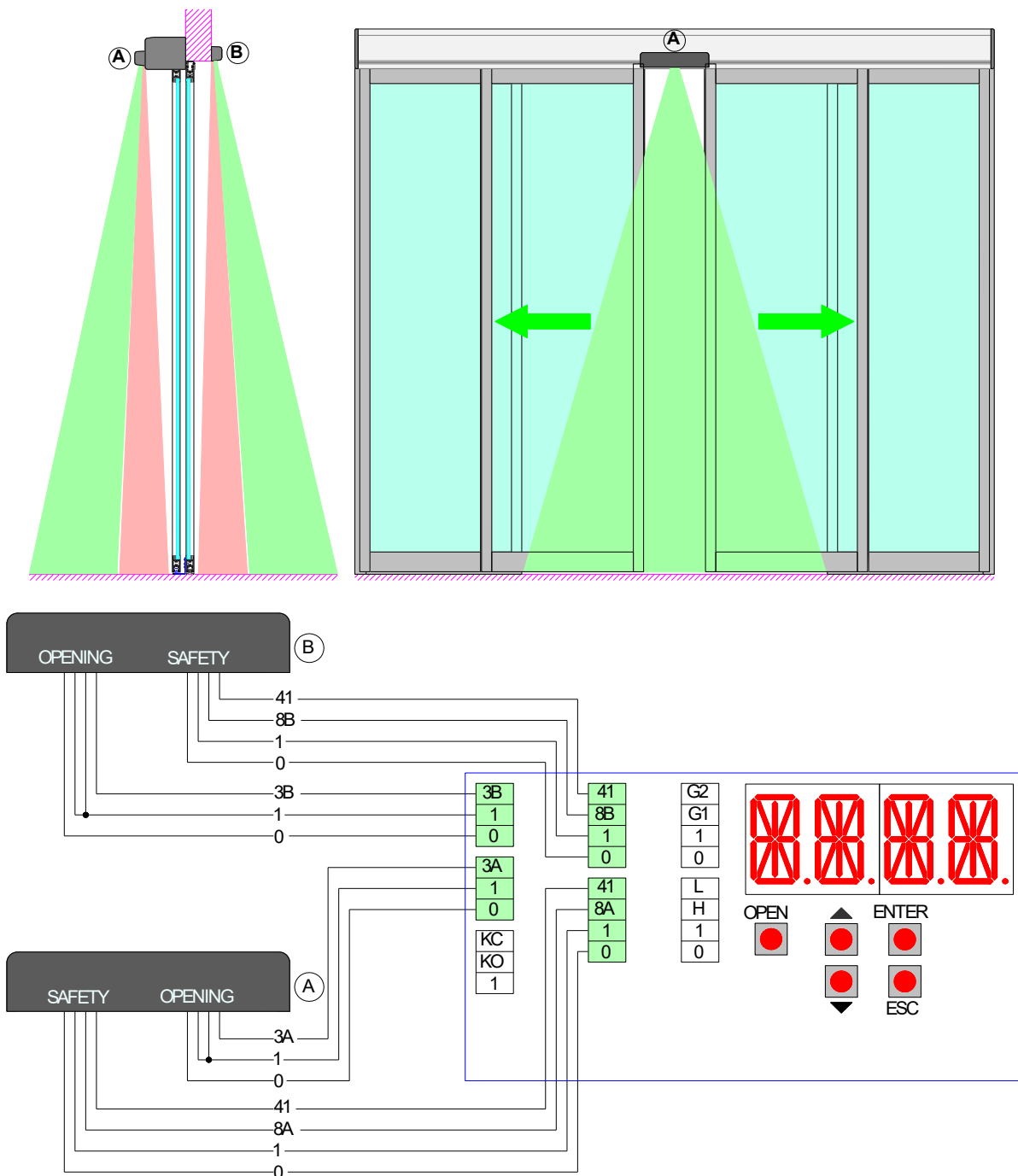

Connect the sensor, using the supplied cable, to the terminals of the electronic control, as follows:

	5CB01	OSD1 (PrimeTec B)	OSD9 (DualSense D)	OSD3 (VIO-DT1) OSD4 (IXIO-DT3)	OSD4 (IXIO-DT3 ARTEK)	OSD5 (3H-IR14C) OSD8 (SSR-3-ER)
OPENING	0	White	White	Brown	Black	Black
	1	Brown Yellow	Brown Yellow	Green Yellow	Red Yellow	Red White
	3A (3B)	Green	Green	White	Yellow	Green
SAFETY	0	Gray	Gray	Blue	Blue	Brown
	1	Red	Red	Pink	Pink	Yellow
	8A (8B)	Blue	Blue	Gray	Pink	Blue
	41	Pink	Pink	Red	Blue	Gray (OSD5: DIP8=ON)
			Purple Black	White / Black Yellow / Black	Yellow / Black Yellow / Red	Light blue Pink

For more information, check the installation manual of the sensor.

7.6 ELECTRICAL CONNECTION OF SAFETY SENSOR

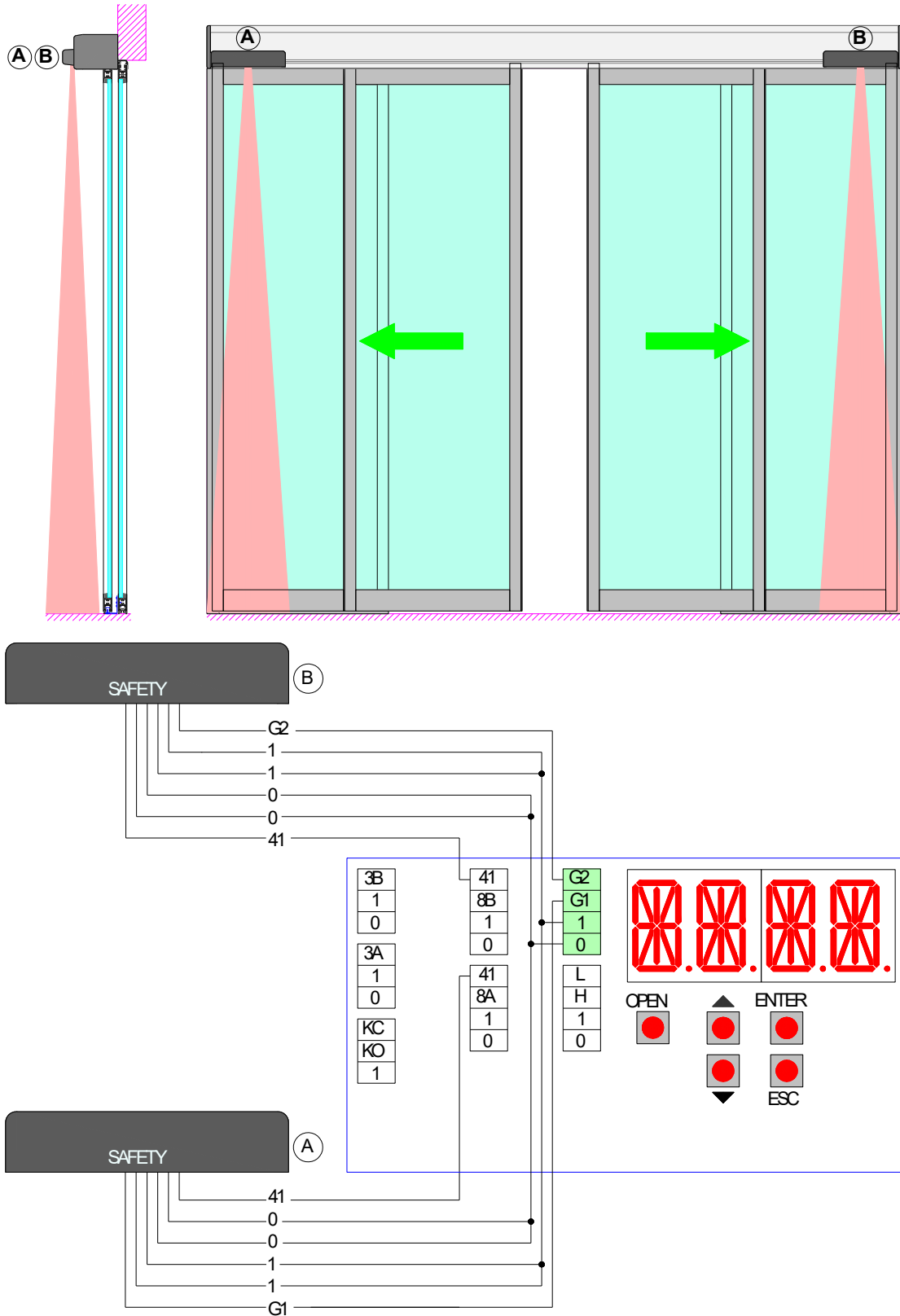

Connect the sensor, using the supplied cable to the terminals of the electronic control as follows:

	5CB08	OSD5 (3H-IR14C)	Notes
SAFETY	0	Black Brown	
	1	Red Yellow	
	G1 (G2)	Blue	Set by menu: ADV > STG1 > SF-A (ADV > STG2 > SF-B)
	41	Gray (DIP8=ON)	

For more information, check the installation manual of the sensor.

8 ELECTRONIC CONTROL ADJUSTEMENT

The electronic control has 4 buttons and 4 alphanumeric displays to set all the necessary adjustments.

After turning on the electronic control, the display shows the word "MENU". The operation of the four keys are indicated in the table.

Keys	Description
ENTER	Select button, each time you press the button you enter on the selected parameter. Save button, pressing for 1 seconds you "SAVE" the selected value. There are the following menu: MENU = Main parameters menu ADV = Advanced parameters menu SEL = Function selector menu MEM = Memory management menu INFO = Information and diagnostics menu
ESC	Exit button, exit from all the parameter or exit from the menu.
↑	Scroll button, each press selects a menu item or increases the value of the selected item.
↓	Scroll button, each press selects a menu item or reduces the value of the selected item.

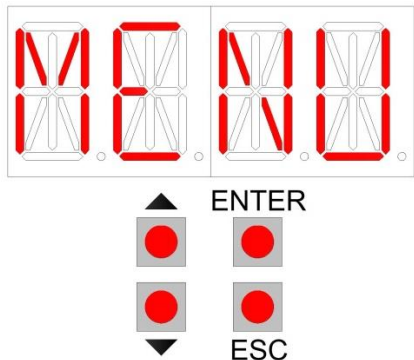

8.1 MENU (MAIN SETTINGS MENU)

Using the buttons ↑ and ↓ choose MENU, press ENTER to select and adjust the following parameters:

(*) Factory settings.

Display	Description
OPEN OPENING DIRECTION	Setting the opening direction. Choose between the following values: ↔ → (*) = 2-leaves door or 1-leaf door opening to right ← = 1-leaf door opening to left
PART PARTIAL OPENING	Setting the percentage of partial opening. Choose between the minimum and maximum: minimum value = 10% maximum value = 90% (*)
VOP OPENING SPEED	Opening speed setting. Choose between the minimum and maximum: minimum value = 100 mm/s maximum value = 800 mm/s (* 500 mm/s)
VCL CLOSING SPEED	Closing speed setting. Choose between the minimum and maximum: minimum value = 100 mm/s maximum value = 800 mm/s (* 300 mm/s)
TAC CLOSING TIME	Open door time setting. Choose between the minimum and maximum: NO = the door is always open minimum value = 1 s (*) maximum value = 30 s
PUSH MOTOR POWER	Force setting. Choose between the minimum and maximum: minimum value = 1 maximum value = 10 (*)
LEAF DOOR WEIGHT	Setting the weight of the door and the friction. Choose between the following values: NO = no leaf MIN (*) = light door / little friction MED = middleweight / average friction MAX = MED = middleweight / average friction
RAMP ACCELERATION	Set the acceleration time. Choose between the minimum and maximum values: SLOW = slow acceleration MED (*) = medium acceleration FAST = fast acceleration
BTMD BATTERY MODE	Setting operation of battery power device, in absence of electricity. Choose between the following values: NO (*) = battery not connected EMER = emergency open CONT = continuation of normal operation of the door Note: the number of operations with battery, depends on the efficiency of the battery, the weight of the doors and the present friction. UNLK = the locking device is released and the door remains stationary. FIRE = priority closing of the door for fire alarm. Note: If the automatic door is turned off for long periods, disconnect the battery from the electronic board.

8.2 ADV (ADVANCED PARAMETERS MENU)

Using the buttons ↑ and ↓ select ADV, press ENTER to select and adjust the following parameters.

(*) Factory settings.

Display	Description
OSSM OPENING SAFETY MOTION	Setting the slowdown distance of the opening sensors (see 6A/6B terminals). Choose between the following values: NO = no slowdown 100 / 200 / 300 / 400 / 500 = the door slows down in the last 100/ 200/ 300/ 400/ 500 mm of opening YES (*) = the door slows down during the whole opening
OSSS OPENING SAFETY STOP	Setting the stopping distance of the opening sensors (see 6A/6B terminals). Choose between the following values: NO (*) = no stop 100 / 200 / 300 / 400 / 500 = the door stops in the last 100/ 200/ 300/ 400/ 500 mm of opening
TYLK LOCK TYPE	Selecting type of locking device. Choose between the following values: LK1 (*) = bistable locking device (SL3LD) LK2 = safety brake device 24Vdc 0,1÷0,4A (SL3SB1)
ELLK LOCK OPERATION TYPE	Selecting type of lock operation. Choose between the following values: AUTO (*) = unlocked with automatic operation while locked with unidirectional operation and door closed UNLK = always unlocked with automatic operation and unidirectional LOCK = always locked the door closed
PUCL PUSH DOOR CLOSED	Setting the push on the closed mechanical stop. Choose between the following values: NO = no push MIN (*) = light push MED = medium push MAX = heavy push
PIPP PUSH DOOR OPEN	Setting of the opening push. Choose between the following values: NO (*) = no push YES = push enabled
PUGO PUSH & GO	Push opening activation. Choose between the following values: NO (*) = disable YES = enable
TAKO KO-CLOSING TIME	Open door time setting, after the 1-KO command. Choose between the minimum and maximum: NO (*) = see MENU > TAC minimum value = 1 s maximum value = 30 s
VTAC VARIABLE CLOSING TIME	Automatic closing time variable in relation of pedestrian traffic. Choose between the following values: NO = disable YES (*) = enable
MOT MOTOR CIRCUIT	Setting the manual friction of the door (only with power supply), by means of the electrical connection of the motor windings. Choose between the following values: OC (*) = manual door opening without friction (motor with open circuit windings) SC = manual door opening with friction (motor with short-circuit windings)
T41 SAFETY TEST	Enable test for safety devices (in accordance with EN 16005). Choose between the following values: NO = test disabled YES (*) = test enable
SYNC DOOR SYNCHRO- NIZATION	Two single-leaf automations with synchronized movement. Choose between the following values. NO (*) = no synchronism MST1 = MASTER automation SLV1 = SLAVE automation MST2 = MASTER external automation (see menu: ADV > INK > EXT) SLV2 = SLAVE external automation (see menu: ADV > INK > EXT)
INK INTER-LOCKED DOOR	Interlocked operation of two automatic doors, the opening of a door is permitted only when the other door is closed. Choose between the following values. NO (*) = no interlock INT = internal door EXT = external door

Display	Description
ID ID NUMBER	If several automations are connected to the network via the 1-H-L terminals, they must have different identification numbers. Choose between the following values: NO (*) = no network 0 / 1 / 2 / 3 / 4 / 5 / 6 / 7 / 8 / 9 / 10 / 11 / 12 / 13 / 14 N.B. After changing the ID, turn the automation off and on again.
PC CLOSING PUSH	Independent setting of the closing force. Choose between the following values: NO (*) = see MENU > PUSH (same force in opening and closing) minimum value = 1 maximum value = 10 Note: if necessary, the closing force (PC) can be set differently from the opening force (PUSH).
STG1 STG2 <i>Setting of G1, G2 input</i>	INPUT COMMANDS BETWEEN 1-G1, 1-G2 TERMINALS NO (*) = no function STOP = Stop contact N.C. The opening of the contact stops the door FIRE = Priority closing command (N.C.), for fire alarm. STEP = Step-by-step contact N.O. The closing of the contact performs in sequence the opening (disabled automatic closure) and the closing of the door. Note: do not use the STEP command with synchronized doors (see ADV > SYNC menu). SAM = Automatic setting command of function selector. The closing and the opening of the contact changes the function selector mode (see menu settings: SEL > SAM1 and SEL > SAM2). EMER = Emergency opening contact N.C. The opening of the contact opens the door. PART = Partial opening contact N.O. (see menu: MENU > PART > 10-90). SF-A = opening safety contact N.C. on side A. SF-B = opening safety contact N.C. on side B. CAB = Step-by-step contact N.O. The closing of the contact performs in sequence the closing of the door (disabling 3A/3B terminals, enabling the signaling for occupied cabin) and the opening of the door (enabling 3A/3B terminals, disabling the signaling for occupied cabin). INKE = Interlocked operation exclusion command between two doors (see menu: ADV > INK). RSET = Reset command KC = Priority closing command (N.O.) SUL = Command to unlock the function selector for 10 seconds
STG2 <i>Setting of G2 output</i>	OUTPUT SIGNALS BETWEEN 0-G2 TERMINALS (12Vdc 30mA) NO (*) = no function BELL = The output is activated for 3 seconds when people enter the store (through the sequential activation of the safety contacts: 1-8B and 1-8A). SERV = The output is activated when the door reaches the number of maintenance cycles, set using the menu: INFO> SERV. WARN = The output is activated when at least one warning remains active for 5 minutes. For remove the alarm signal make a reset or turn off the power supply. CLOS = The output is activated when the door is closed OPEN = The output is activated when the door is open AIR = The output is activated when the door is not closed LAMP = The output is activated when the door is moving CABS = Signaling of the occupied cabin (see menu: ADV > STG1 > CAB) INK = Red traffic light signaling for interlocked doors (see menu: ADV > INK) PWOFF = The output is activated in the absence of power supply (W128) HAND = The output is activated when the door is opened by hand FS = The output is activated when the door is not closed, in the presence of a fire alarm. 3AS = The output is activated when input 3A is not active 3BS = The output is activated when input 3B is not active

(*) Factory settings. ATTENTION: terminals G1, G2 cannot have the same settings.

8.3 SEL (FUNCTION SELECTOR MENU)

Using the buttons ↑ and ↓ select SEL, press ENTER to select and adjust the following parameters.

(*) Factory settings.

Display	Description
MODE SELECTOR MODE	<p>Displaying of operating mode of function selector device. Choose between the following values:</p> <p>NO (*) = no mode</p> <p>OPEN = open door</p> <p>AUTO = automatic bi-directional operation</p> <p>CLOS = closed door</p> <p>1D = automatic one-way operation</p> <p>PA = automatic partial operation</p> <p>1DPA = automatic one-way operation and partial</p>
SECL SELECTOR LOCK	<p>How to activate the function selector. Choose between the following values:</p> <p>NO (*) = function selector always accessible</p> <p>LOGO = function selector accessible by selecting the logo for 3 seconds</p> <p>TAG = function selector accessible with badge and numeric code</p>
DLAY DELAY CLOSED DOOR	<p>Setting delay time function closed door. Choose between the minimum and maximum values:</p> <p>minimum value = 1 s (*)</p> <p>maximum value = 5 min</p>
TMEM TAG MEMORISE	<p>Saving procedure of badge and numeric code for function selector. Choose between the following values.</p> <p>NO (*) = no saving</p> <p>SMOD = Saving badge and numeric code for activation of the function selector.</p> <p>OPEN = Saving badge and numeric code for activation of priority opening: proceed as SMOD</p> <ul style="list-style-type: none"> - press the ENTER button for 1 second, the display shows REDY, <p>FSD5 - approach the badge to the function selector (in front of the NFC symbol), the display shows the badge code,</p> <p>FSD6 - press the logo, enter the code (from 1 to 5 numbers), press the logo for confirmation, the display shows the numeric code (Note: the numeric code can be stored only if SECL=TAG),</p> <ul style="list-style-type: none"> - wait for 2 minutes or press the ESC button. <p>Note: if the badge and the numeric code is not recognized the display shows the message UNKN.</p> <p>You can store a total maximum of 40 badges and numeric codes.</p> <p>APP = Saving phone for activation of the FACE PRC and FACE URC App</p> <ul style="list-style-type: none"> - press the ENTER button for 1 second, the display shows REDY, <p>FSD5 – stay with the phone near the function selector (in the Bluetooth range).</p> <ul style="list-style-type: none"> - wait for 2 minutes or press the ESC button.
TMAS TAG MASTER	<p>It is possible to create master badge and master numeric code that allows the saving of the badges and the numeric codes, without the use of the menu. Choose from the following values.</p> <p>NO (*) = no saving</p> <p>MMOD = creation of the master badge and master numeric code to saving badges and numeric codes for function selector activation: proceed as SMOD.</p> <p>MOPE = creation of the master badge and master numeric code to saving the badges and numeric codes of opening priority: proceed as OPEN.</p> <p>Note: if the badge and the numeric code is not recognized the display shows the message UNKN.</p> <p>FSD5 - The use of the master badge is the following:</p> <ul style="list-style-type: none"> - approach the master badge to the function selector (in front of the NFC symbol), the buzzer emits 2 beeps at the beginning of the storage procedure, - approach the badges, that you want to store, one at a time, to the function selector (in front of the NFC symbol), the buzzer emits 1 beep of confirmation storage, - wait for 2 minutes, the buzzer emits 2 beeps at the end of the storage procedure. <p>FSD6 - The use of the master numeric code is the following:</p> <ul style="list-style-type: none"> - press the logo, enter the master numeric code, press the logo for confirmation, the buzzer emits 2 beeps at the beginning of the storage procedure, - press the logo, enter the new code (from 1 to 5 numbers), press the logo for confirmation,, the buzzer emits 1 beep of confirmation storage, - wait for 2 minutes, the buzzer emits 2 beeps at the end of the storage procedure. <p>Note: if the badge and the numeric code is not stored, the buzzer emits no beeps.</p>

Display	Description
TDEL TAG DELETE	<p>Cancellation procedure of badge and numeric code. Choose between the following values.</p> <p>NO (*) = no cancellation</p> <p>YES = badge and numeric code cancellation</p> <p>- press the ENTER button for 1 second, the display shows REDY,</p> <p>FSD5 - approach the badge to the function selector (in front of the NFC symbol), the display shows the badge code,</p> <p>FSD6 - press the logo, enter the code (from 1 to 5 numbers), press the logo for confirmation, the display shows the numeric code.</p> <p>- wait for 2 minutes or press the ESC button.</p> <p>Note: if the badge and the numeric code is not recognized the display shows the message UNKN.</p>
TERA TAG TOTAL ERASE	<p>How to erase all stored badges and numeric codes. Choose between the following values:</p> <p>NO (*) = no erase</p> <p>YES = cancellation of all badges and numeric codes</p>
SAM1 SELECTOR AUTOMATIC MODE	<p>First setting of function selector, when the 1-G1 (1-G2) contact becomes closed. Set the menu ADV > STG1 (STG2) > SAM.</p> <p>Connect the contact of a clock to 1-G1 (1-G2) terminals, and choose between the following values:</p> <p>OPEN = open door</p> <p>AUTO = automatic bi-directional operation</p> <p>CLOS (*) = closed door</p> <p>1D = automatic one-way operation</p> <p>PA = automatic partial operation</p> <p>1DPA = automatic one-way operation and partial</p>
SAM2 SELECTOR AUTOMATIC MODE	<p>Second setting of function selector, when the 1-G1 (1-G2) contact becomes open. Set the menu ADV > STG1 (STG2) > SAM.</p> <p>Connect the contact of a clock to 1-G1 (1-G2) terminals, and choose between the following values:</p> <p>OPEN = open door</p> <p>AUTO = automatic bi-directional operation</p> <p>CLOS (*) = closed door</p> <p>1D = automatic one-way operation</p> <p>PA = automatic partial operation</p> <p>1DPA = automatic one-way operation and partial</p>
FW FIRMWARE UPGRADE	<p>Programming procedure of function selector.</p> <p>Insert the USB/micro SD memory in the electronic control.</p> <p>From this menu, choose the firmware version you want.</p> <p>Press ENTER until it starts the programming procedure that lasts about 30 seconds, at the end the display shows "SAVE".</p> <p>After the procedure, remove the USB/micro SD memory from the electronic control and store it for future use.</p> <p>Note: in the case of programming error or missing firmware (W103), proceed as follows: disconnect the power supply, insert the USB/micro SD memory, give power supply, and repeat the programming procedure from this menu.</p>
VER VERSION	<p>Displaying the firmware version of function selector.</p>
TIN TAG INPUT	<p>You can upload the badges and numeric codes used in another automation, already stored in the USB/micro SD memory. Choose between the following values:</p> <p>NO (*) = no upload</p> <p>YES = upload the badges and numeric codes from the USB/micro SD memory</p>
TOUT TAG OUTPUT	<p>You can save the stored badges and numeric codes in the USB/micro SD memory. Choose between the following values:</p> <p>NO (*) = no save</p> <p>YES = save the stored badges and numeric codes in the USB/micro SD memory</p>

8.4 MEM (MEMORY MANAGEMENT MENU)

Using the buttons ↑ and ↓ select MEM, press ENTER to select and adjust the following parameters.

(*) Factory settings.

Display	Description
FSET FACTORY SETTINGS	Restore all settings to factory defaults. Choose between the following values: NO (*) = no restore. YES = restore to factory settings.
FW FIRMWARE UPGRADE	Programming procedure of electronic control. Insert the USB/micro SD memory in the electronic control. From this menu, choose the firmware version you want. Press ENTER until it starts the programming procedure that lasts about 30 seconds, at the end the display shows "SAVE". After the procedure, remove the USB/micro SD memory from the electronic control and store it for future use. Note: in the case of programming error or missing firmware (W100), proceed as follows: disconnect the power supply, insert the USB/micro SD memory, give power supply, the programming procedure starts automatically, or choose the firmware from this menu.
SIN SETTING INPUT	You can upload the menu settings used in another automation, already stored in the USB/micro SD memory. Choose between the following values: NO (*) = no upload YES = upload the menu settings from the USB/micro SD memory
SOUT SETTING OUTPUT	You can save the menu settings of automation in use, in the USB/micro SD memory. Choose between the following values: NO (*) = no save YES = save the menu settings of automation in the USB/micro SD memory

8.5 INFO (INFORMATION AND DIAGNOSTICS MENU)

Using the buttons ↑ and ↓ select INFO, press ENTER to select and adjust the following parameters.

(*) Factory settings.

Display	Description
SHOW DISPLAY INFO	Displaying information of warning and faults. Choose between the following values: CONT (*) = the display shows the active contacts of the terminal blocks and the alarms. WARN = the display shows the alarms only.
VER VERSION	Displaying the firmware version of electronic control.
CYCL CYCLES	Shows the number of cycles of the door (1 = 1.000 cycles, 9000 = 9.000.000 cycles).
SERV SERVICE SIGNAL	Enabling the signaling of routine maintenance of the door. NO (*) = no signaling 1 = 1.000 cycles / 9000 = 9.000.000 cycles
LOG INFO FILE	You can save the following information in the USB/micro SD memory (sliding_log.txt): the last 20 warnings, the menu settings, and the electronic devices connected to automation. Choose between the following values: NO (*) = no save YES = save the information in the USB/micro SD memory
WARN WARNING LIST	Displaying of the last 10 warnings (the warning number 0 is the last): 0.xxx / 1.xxx / 2.xxx / 3.xxx / 4.xxx / 5.xxx / 6.xxx / 7.xxx / 8.xxx / 9.xxx

DISPLAY	SEL	FLASH	WARNING	CHECK
W001		1	Encoder error	Check encoder connection
W002		1	Motor short circuit	Check the connection of the motor
W003		1	Motor control error	Electronic control failure
W010		2	Direction reversed	Check the presence of obstacles
W011		2	Running too long	Check the connection of the belt
W012		2	Running too short	Check the presence of obstacles
W013		2	Overrun	Check the mechanical stops
W100	-	-	Programming error	Repeat the programming procedure in MEM > FW menu
W103	-	-	Programming error Selector	Repeat the programming procedure in SEL > FW menu
W127	-	-	Automation reset	The automation performs a self-test
W128		on	No power supply	Check the power supply
W129		1	No battery	Check the battery connection
W130		1	Low Battery	Replace or recharge the battery
W140		3	6A safety test failure	Check the safety sensor connection
W141		3	6B safety test failure	Check the safety sensor connection
W142		3	8A safety test failure	Check the safety sensor connection
W143		3	8B safety test failure	Check the safety sensor connection
W145		4	Motor overtemperature (first step)	The door reduces the speed
W146		4	Motor overtemperature (second step)	The door stops
W148		1	Locking device overcurrent	Check the ADV > TYLK menu and the lock connection
W150		2	Obstacle in opening	Check the presence of obstacles
W151		2	Obstacle in closing	Check the presence of obstacles
W152		2	Door locked open	Check the presence of locks
W153		2	Door locked closed	Check the presence of locks
W160		1	Synchronization error	Check the ADV > SYNC and ADV > INK menu
W256	-	-	Power on	-
W257	-	-	Firmware update	-
W320		on	Signaling of maintenance	Check the INFO > SERV menu
W330		1	Tuning between motor and electronics	Wait about 3-30 seconds

8.6 LOW ENERGY

To reduce the force and kinetic energy of the door, make the following adjustments.

Adjust the force PUSH ≤ 8 .

Adjust the opening speed (VOP) so as to open the door (90%) at the times indicated in the table.

Adjust the closing speed (VCL) so as to close the door (90%) at the times indicated in the table.

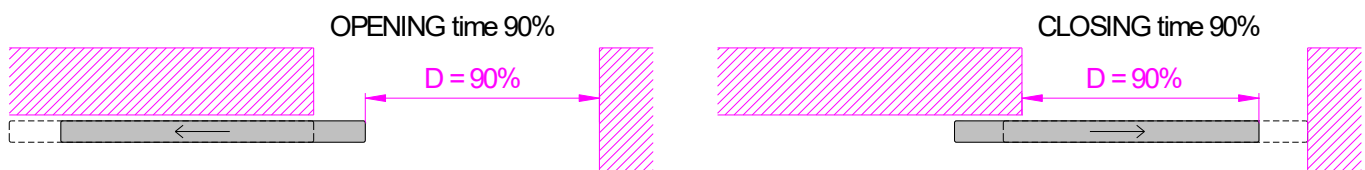

D [m]	Door weight [kg]														
	150	140	130	120	110	100	90	80	70	60	50	40	30	20	10
	Maximum speed [m/s]														
	0,15	0,16	0,16	0,17	0,18	0,18	0,19	0,21	0,22	0,24	0,26	0,29	0,34	0,41	0,58
	Time [s]														
0,7	4,7	4,6	4,4	4,2	4,0	3,9	3,7	3,5	3,2	3,0	2,7	2,5	2,1	1,8	1,3
0,8	5,4	5,2	5,0	4,8	4,6	4,4	4,2	3,9	3,7	3,4	3,1	2,8	2,4	2,0	1,4
0,9	6,0	5,8	5,6	5,4	5,2	4,9	4,7	4,4	4,1	3,8	3,5	3,1	2,7	2,2	1,6
1,0	6,7	6,5	6,3	6,0	5,8	5,5	5,2	4,9	4,6	4,3	3,9	3,5	3,0	2,5	1,8
1,1	7,4	7,1	6,9	6,6	6,3	6,0	5,7	5,4	5,1	4,7	4,3	3,8	3,3	2,7	1,9
1,2	8,0	7,8	7,5	7,2	6,9	6,6	6,2	5,9	5,5	5,1	4,7	4,2	3,6	3,0	2,1
1,3	8,7	8,4	8,1	7,8	7,5	7,1	6,8	6,4	6,0	5,5	5,0	4,5	3,9	3,2	2,3
1,4	9,4	9,1	8,7	8,4	8,0	7,7	7,3	6,9	6,4	5,9	5,4	4,9	4,2	3,5	2,5
1,5	10,0	9,7	9,4	9,0	8,6	8,2	7,8	7,3	6,9	6,4	5,8	5,2	4,5	3,7	2,6

9. START-UP PROCEDURE OF THE AUTOMATIC SLIDING DOOR

9.1 Preliminary checks.

At the end of the installation, move the doors manually and make sure that operation is smooth and without friction. Check the solidity of the structure and the proper attachment of all the screws. Check the correctness of all electrical connections.

Before connecting any security devices, leave the jumper on terminals safety (41-8A, 41-8B).

9.2 Giving power supply and connect the battery, if present.

Note: every time you switch on the automation performs a self-test (from 3 to 30 seconds). The first opening and closing cycle is at low speed to allow the automatic learning.

To ensure that the electronic control has the factory settings, restore via the menu:

MEM > FSET = YES (confirm by pressing ENTER for 1 second).

Note: if the door is 1-leaf opening to the left, set the opening direction as follows:

MENU > OPEN = ← (confirm by pressing ENTER for 1 second).

Perform the menu settings as described in Chapter 8. Use OPEN button to perform the opening door, and verify the correct operation of the door.

Note: the automation automatically detects any obstacles during the closing movement (reversal movement) and opening (stopping movement).

9.3 Connect one at a time, opening and safety devices to protect the closing cycle of the door, as described in Chapter 7.5, and verify proper operations.

Note: verify that the opening access is properly protected by safety sensors, in accordance with the requirements of the European standard EN16005 (annex C).

Note: verify that the opening access is properly protected by safety sensors, in accordance with the requirements of the European standard EN16005 (annex C).

Connect one at a time, safety devices to protect the opening cycle of the door, as described in Chapter 7.6, and verify proper operations.

Note: if the gap between the door and the fixed parts meet the requirements of the European standard EN16005 (Chapter 4.6.2.1.a), the safety sensors are not needed ($X \leq 100$ e $Y \geq 200$).

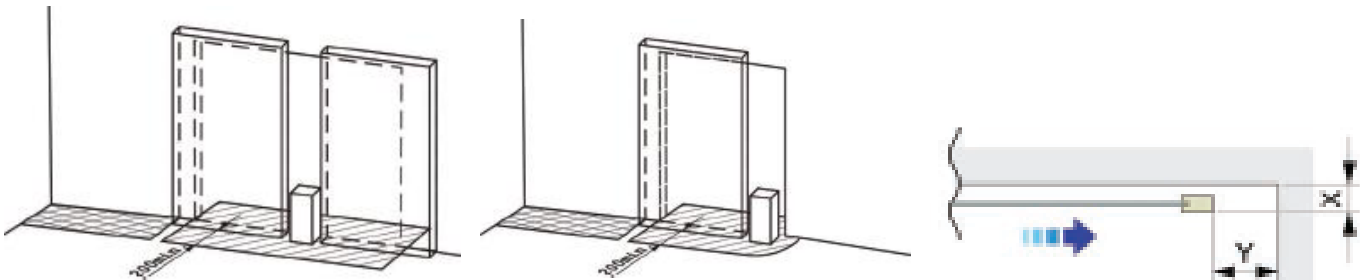

9.4 If the risk assessment of the door allows protection through Low Energy, make adjustments in accordance with the requirements of the European standard EN16005 (Annex F2), as indicated in chapter 8.6.

9.5 At the end of the automation starting, deliver to the owner the user instructions, including all warnings and information necessary to maintain the security and functionality of the automatic door.

Automations are feature of label on the right end cap, containing the required information by European standards EN16005 and EN60335-2-103.

Note: the manufacturer of the automatic sliding door have to add his own label identifying the installation.

FACE S.r.l.	www.facespa.it
Viale delle Industrie,74 - 31030 Dosson di Casier (TV)	
Type: SL3L	Standard: EN16005
DRIVE UNIT FOR SLIDING DOOR	
Input: 100-240V 50/60Hz Power: 60W	
Load: 80N	
Tmin: -15°C Tmax: +50°C IP20	
s/n: 1807 0001 Year: 2018	
CE	
0040818070001	

10. TROUBLESHOOTING

In addition to the following list of possible problems, there are warnings provided by the display, as described in chapter 8.5.

Problem	Possible causes	Remedy
The automation does not open or close.	No power supply (display off).	Check the power supply.
	Short circuited external accessories.	Disconnect all accessories from terminals 0-1 and reconnect them one at a time (check for voltage 12V).
	The door is locked by bolts and locks.	Check the freely move of the doors
The automation does not perform the functions set.	Function selector incorrectly set.	Check and correct the settings of the function selector.
	Control devices or safety always activated.	Disconnect devices from the terminal and verify the operation of the door.
The movement of the doors isn't linear, or reverse the movement for no reason.	The automation does not successfully perform the automatic learning.	Perform a reset using the command 1-29 , or power off and power on the automation.
The automation opens but does not close	Anomalies during the safety devices test.	Jumper contacts one at a time 41 -8A , 41 -8B.
	The opening devices are activated.	Verify that the opening sensors are not subject to vibration , do not perform false detections or the presence of moving objects in the field of action.
	The automatic closing doesn't work.	Check the settings of the function selector .
Safety devices not activating.	Incorrect connections between the safety devices and electronic control.	Check that the safety contacts of the devices are properly connected to the terminal blocks and the relative jumpers have been removed.
The automation opens by itself.	The opening and safety devices are unstable or detect moving bodies	Verify that the opening sensors are not subject to vibration , do not perform false detections or the presence of moving bodies in the field of action.
The locking device doesn't lock or unlock the doors.	Wrong connection of the locking device to the electronic control.	Check the correct color connection of the locking device
	The attachment lock brackets, fixed on carriage, will not release	Check the adjustment of the position of the brackets coupling lock.
	Pulling the release cord don't unlock the doors.	Check the correct fitting of the release cord on the lock.

11. AUTOMATIC SLIDING DOOR ROUTINE MAINTENANCE PLAN

To ensure proper operation and safe use of the automatic door, as required by European standard EN16005, the owner has to perform routine maintenance by qualified personnel. Except for routine cleaning of the door and any floor rails, that are under the responsibility of the owner, all maintenance and repair work must be carried out by qualified personnel. The following table lists tasks related to routine maintenance, and the frequency of intervention related to an automatic sliding door operation with standard conditions. In the case of more severe operating conditions, or in the case of sporadic use of the automatic sliding door, the frequency of maintenance can be consistently adequate.

Task	Frequency
Remove the power supply, open the automation and perform the following checks and adjustments. - Check all screws fastening of components within the automation. - Check the cleanliness of carriage and rail. - Check the correct belt tension. - Check the state of belt wear and carriage wheels (if necessary replace them). - Check the correct fitting of the doors on the carriages . - If present, verify proper engagement of the locking device and the operation of the release cord.	Every 6 months or every 200.000 cycles.
Connect the power supply and perform the following checks and adjustments. - Check the correct operation of the control devices and safety. - Check the detection area of the security sensors complies with the requirements of the European standard EN16005. - If present, verify the correct operation of the locking device. - If present, verify the correct operation of the battery power device (if necessary replace the battery).	Every 6 months or every 200.000 cycles. Note: the verification of the automation security functions and safety devices must be made at least 1 time per year.

All maintenance, replacement, repair, update, etc.. must be written into the proof book, as required by European standard EN16005, and delivered to the owner of the automatic sliding door. For repairs or replacements of products, original spare parts must be used.

11.1 DISPOSAL OF PRODUCTS



The packaging materials (cardboard, plastic, and so on) should be disposed of as solid household waste, and simply separated from other waste for recycling. Our products are made of various materials. Most of these (aluminum, plastic, iron, electrical cables) are classified as solid household waste. They can be recycled by separating them before dumping at authorized city plants. Whereas other components (control boards, batteries, and so on) may contain hazardous pollutants. These must therefore be disposed of by authorized, certified professional services. Before disposing, it is always advisable to check with the specific laws that apply in your area. **DO NOT DISPOSE IN THE ENVIRONMENT.**

DECLARATION OF INCORPORATION (FOR UK MARKET ONLY)
 The Supply of Machinery (Safety) Regulations 2008, Annex II-B



FACE S.r.l. - Viale delle Industrie, 74 - 31030 Dosson di Casier (TV) - ITALY

Declares that the Product automations for power operated pedestrian sliding door type: SL3L.

Has been built for installation on pedestrian door and constitutes a machine in accordance with The Supply of Machinery (Safety) Regulations 2008. The manufacturer of the power operated pedestrian door must declare its conformity in accordance with The Supply of Machinery (Safety) Regulations 2008, prior to starting-up the machine.

It complies with the applicable essential safety requirements specified in The Supply of Machinery (Safety) Regulations 2008, Annex I: 1.1.2, 1.1.3, 1.2, 1.3.1, 1.3.2, 1.3.4, 1.3.7, 1.3.8, 1.4, 1.5.1, 1.5.2, 1.5.10, 1.5.11, 1.5.14, 1.6.1, 1.6.3, 1.7

It complies with the Electromagnetic Compatibility Regulations 2016.

It complies with following harmonized standards:

EN 16005 Power operated pedestrian doorsets - Safety in use - Requirements and test methods

EN 60335-2-103 Household and similar electrical appliances - Safety - Part 2: Particular requirements for drives for gates, doors and windows

The technical documentation complies with The Supply of Machinery (Safety) Regulations 2008, Annex VII-B.

The technical documentation is managed by: Ferdinando Menuzzo with registered offices in Viale delle Industrie, 74 - 31030 Dosson di Casier (TV) - ITALY

A copy of the technical documentation shall be supplied to the competent national authorities following duly motivated request.

Place and date:
 Dosson di Casier, 2022-10-01

 Paolo Bacchin
 Managing Director