



INSTALLATION AND MAINTENANCE MANUAL FOR SLIDING DOOR



SL4A-SL5A-SL6A	ADVANCED
SL4E-SL5E-SL6E	EMERGENCY
SL5H-SL6H	HEAVY
SL6B	BIG
SLTA	TELESCOPIC-ADVANCED
SLTE	TELESCOPIC-EMERGENCY

1. INTRODUCTION

Before you begin to install or start an automatic pedestrian doors, an inspection must be carried out on site by qualified personnel, for making measurements of the compartment wall, door and drive.

This inspection is to assess the risk and to select and implement the most appropriate solutions according to the type of pedestrian traffic (intense, narrow, one-way, bi-directional, etc.), The type of users (elderly, disabled, children, etc.), in the presence of potential hazards or local circumstances.

To assist installers in applying the requirements of European Standard EN 16005 concerning the safe use of automatic pedestrian doors, we recommend consulting the guides E.D.S.F. (European Door and Shutter Federation) available on www.edsf.com.

1.1 GENERAL SAFETY INSTRUCTION

This installation manual is intended for professionally competent personnel only. Before installing the product, carefully read the instructions.

Bad installation could be hazardous. The packaging materials (plastic, polystyrene, etc.) should not be discarded in the environment or left within reach of children, as these are a potential source of hazard.

Before installing the product, make sure it is in perfect condition. Do not install the product in an explosive environment and atmosphere: gas or inflammable fumes are a serious hazard risk.

Before installing the automations, make all structural changes relating to safety clearances and protection or segregation of all areas where there is risk of being crushed, cut or dragged, and danger areas in general.

Make sure the existing structure is up to standard in terms of strength and stability. FACE is not responsible for failure to use Good Working Methods in building the frames to be motorised or for any deformation occurring during use.

The safety devices (safety sensor, photocells, etc.) must be installed taking into account: applicable laws and directives, Good Working Methods, installation premises, system operating logic and the forces developed by the motorised door.

Apply hazard area notices required by applicable regulations.

The emission sound pressure level of the door is $LpA \leq 70dB(A)$.

Each installation must clearly show the identification details of the automatic pedestrian door.

The product, in its original packaging supplied by the manufacturer, must only be transported in a closed environment (railway carriage, containers, closed vehicles).

If the product malfunctions, stop using it and contact an authorised support centre.

The manufacture date is provided in the production batch printed on the product label. If necessary, contact us at www.facespa.it.

The general conditions of sale are given in the official FACE price lists.

1.2 CE MARKING AND EUROPEAN DIRECTIVES



Automations for sliding pedestrian, are designed and manufactured in compliance with the safety requirements of the European standard EN 16005 and are CE-marked in accordance with the Electromagnetic Compatibility Directive (2014/30/UE).

The automation also include a Declaration of Incorporation according to the Machinery Directive (2006/42/EC).

Pursuant to Machinery Directive (2006/42/CE) the installer who motorises a door or gate has the same obligations as the manufacturer of machinery and as such must:

- prepare the technical file which must contain the documents indicated in Annex V of the Machinery Directive; (The technical file must be kept and placed at the disposal of competent national authorities for at least ten years from the date of manufacture of the pedestrian door);
- draft the EC declaration of conformity in accordance with Annex II-A of the Machinery Directive and deliver it to the customer;
- affix the CE marking on the power operated door in accordance with point 1.7.3 of Annex I of the Machinery.

All data and information contained in this manual have been drawn up and checked with the greatest care. However FACE cannot take any responsibility for eventual errors, omissions or inaccuracies due to technical or illustrative purposes.

FACE reserves the right to make changes and improvements to their products. For this reason, the illustrations and the information appearing in this document are not definitive.

This edition of the manual cancels and replaces all previous versions. In case of modification will be issued a new edition.



DECLARATION OF INCORPORATION

Machines Directive 2006/42/EC, Annex II-B



FACE S.r.l.

Viale delle Industrie, 74 - 31030 Dosson di Casier (TV) - ITALY

Declares that:

The Product automations for power operated pedestrian sliding door type:

SL4A, SL4E, SL5A, SL5E, SL5H, SL6A, SL6E, SL6H, SL6B, SLTA, SLTE.

Has been built for installation on pedestrian door and constitutes a machine in accordance with Directive 2006/42/EC. The manufacturer of the power operated pedestrian door must declare its conformity in accordance with Directive 2006/42/EC (Annex II-A) prior to starting-up the machine.

It complies with the applicable essential safety requirements specified in Annex I, chapter 1 of Directive 2006/42/EC:

1.1.2, 1.1.3, 1.2, 1.3.1, 1.3.2, 1.3.4, 1.3.7, 1.3.8, 1.4, 1.5.1, 1.5.2, 1.5.10, 1.5.11, 1.5.14, 1.6.1, 1.6.3, 1.7

It complies with the Electromagnetic Compatibility Directive 2014/30/UE.

It complies with following harmonized standards:

EN 16005 Power operated pedestrian doorsets - Safety in use - Requirements and test methods

EN 60335-2-103 Household and similar electrical appliances - Safety - Part 2: Particular requirements for drives for gates, doors and windows

The technical documentation complies with Annex VII-B to Directive 2006/42/EC.

The technical documentation is managed by: Ferdinando Menuzzo with registered offices in Viale delle Industrie, 74 - 31030 Dosson di Casier (TV) - ITALY

A copy of the technical documentation shall be supplied to the competent national authorities following duly motivated request.

Place and date:

Dosson di Casier, 2022-09-01

Paolo Bacchin
Managing Director

A handwritten signature in blue ink, appearing to read "Paolo Bacchin", is written over the printed name and title.

FACE S.r.l.

Viale delle Industrie, 74

31030 – Dosson di Casier (TV) Italy

Phone +39 0422 492730 Fax +39 0422 380414

www.facespa.it

Iscritta al Reg. Imp. di Treviso al n. 04552520266

C.F.-P.I. 04552520266



Capitale Sociale € 100.000,00 i.v.



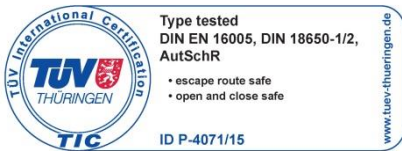

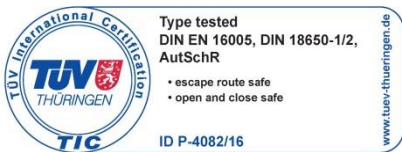



R.E.A. di Treviso n. 359250

2. TECHNICAL DATA

Features	SL4A – SL5A – SL6A	SL4E – SL5E – SL6E
Automation type	ADVANCED	EMERGENCY
Certification	 <p>Type tested DIN EN 16005, DIN 18650-1/2</p> <ul style="list-style-type: none"> • open and close safe <p>ID P-4070/15</p>	 <p>Type tested DIN EN 16005, DIN 18650-1/2, AutSchR</p> <ul style="list-style-type: none"> • escape route safe • open and close safe <p>ID P-4071/15</p>
Max product dimensions: Height x Depth x Maximum length	125 x 156 x 6600 mm	125 x 156 x 6600 mm
Maximum weight of door 1 leaf: Maximum weight of door 2 leaves:	SL4A = 1 x 100 kg SL5A-SL6A = 1 x 140 kg SL4A = 2 x 90 kg SL5A-SL6A = 2 x 120 kg	SL4E = 1 x 100 kg SL5E-SL6E = 1 x 140 kg SL4E = 2 x 90 kg SL5E-SL6E = 2 x 120 kg
Average life (**)	5.000.000 cycles	5.000.000 cycles

Features	SLTA	SLTE
Automation type	TELESCOPIC-ADVANCED	TELESCOPIC-EMERGENCY
Certification	 <p>Type tested DIN EN 16005, DIN 18650-1/2</p> <ul style="list-style-type: none"> • open and close safe <p>ID P-4081/16</p>	 <p>Type tested DIN EN 16005, DIN 18650-1/2, AutSchR</p> <ul style="list-style-type: none"> • escape route safe • open and close safe <p>ID P-4082/16</p>
Max product dimensions: Height x Depth x Maximum length	125 x 216 x 6600 mm	125 x 216 x 6600 mm
Maximum weight of door 2 leaves: Maximum weight of door 4 leaves:	2 x 100 kg 4 x 70 kg	2 x 100 kg 4 x 70 kg
Average life (**)	3.000.000 cycles	3.000.000 cycles

Features	ADVANCED	EMERGENCY
Maximum opening and closing speed: Sliding door 1 door Sliding door 2 doors	0,8 m/s 1,6 m/s	0,8 m/s 1,6 m/s
Duty class Intermittent operation	Continuous operation 100%	Continuous operation 100%
Power supply Rated power Stand-by	100–240 Vca 50/60 Hz 70 W 10 W	100–240 Vca 50/60 Hz 70 W 10 W
Rated load	150 N	150 N
Protection Rating	IP 20	IP 20
Operating temperature Storage temperature (*)	 <p>-15 °C +50 °C -20 °C +70 °C</p>	 <p>-15 °C +50 °C -20 °C +70 °C</p>
Power output for accessories	12 Vdc (1 A max)	12 Vdc (1 A max)
Memory for settings and saving	USB / micro SD	USB / micro SD
Electronic function selector	FSD5, FSD6	FSD5, FSD6
Bistable locking device	SL5LD	SL5LD + SL5SL
Super capacitor for emergency opening	SLCOD	SLCOD
Battery power device	SL5BD, SL5BD1, SL5BD2	SL5BD2
Fixing device for sensor	SL5FS	SL5FS

Features	SL5H – SL6H	SL6B
Automation type	HEAVY	BIG
Max product dimensions: Height x Depth x Maximum length	125 x 156 x 6600 mm	125 x 156 x 6600 mm
Maximum weight of door 1 leaf: Maximum weight of door 4 leaves:	1 x 180 kg 2 x 150 kg	1 x 400 kg 2 x 250 kg
Maximum opening and closing speed: Sliding door 1 door Sliding door 2 doors	0,6 m/s 1,2 m/s	0,3 m/s 0,6 m/s
Duty class Intermittent operation	Intensive operation S3 = 60%	Intensive operation S3 = 60%
Power supply Rated power Stand-by	100–240 Vca 50/60 Hz 70 W 10 W	100–240 Vca 50/60 Hz 70 W 10 W
Rated load	150 N	350 N
Protection Rating	IP 20	IP 20
Operating temperature Storage temperature (*)	 -15 °C  +50 °C  -20 °C  +70 °C	 -15 °C  +50 °C  -20 °C  +70 °C
Average life (**)	1.000.000 cycles	1.000.000 cycles
Power output for accessories	12 Vdc (1 A max)	12 Vdc (1 A max)
Memory for settings and saving	USB / micro SD	USB / micro SD
Electronic function selector	FSD5, FSD6	FSD5, FSD6
Bistable locking device	SL5LD	SL5LD
Super capacitor for emergency opening	SLCOD	SLCOD
Battery power device	SL5BD, SL5BD1, SL5BD2	SL5BD, SL5BD1, SL5BD2
Fixing device for sensor	SL5FS	SL5FS

(*) Before installing the product, keep it at room temperature where it has previously been stored or transported at a very high or very low temperature.

(**) The average product life specified should be understood purely as an indicative estimate. It applies to normal usage conditions and where the product has been installed and maintained in compliance with the instructions provided in the technical manual. The average product life is also affected, including significantly, by other variables such as, but not limited to, climatic and environmental conditions. The average product life should not be confused with the product warranty.

Note: The technical data above refer to average conditions of use and cannot be certain in each case. Each automatic entrance variables such as: friction, balancing and environmental conditions may substantially change both the duration and the quality of the operation of the automatic entrance or some of its components, including the automation. The installer must adopt adequate safety coefficients for each particular installation.

3. STANDARD INSTALLATION

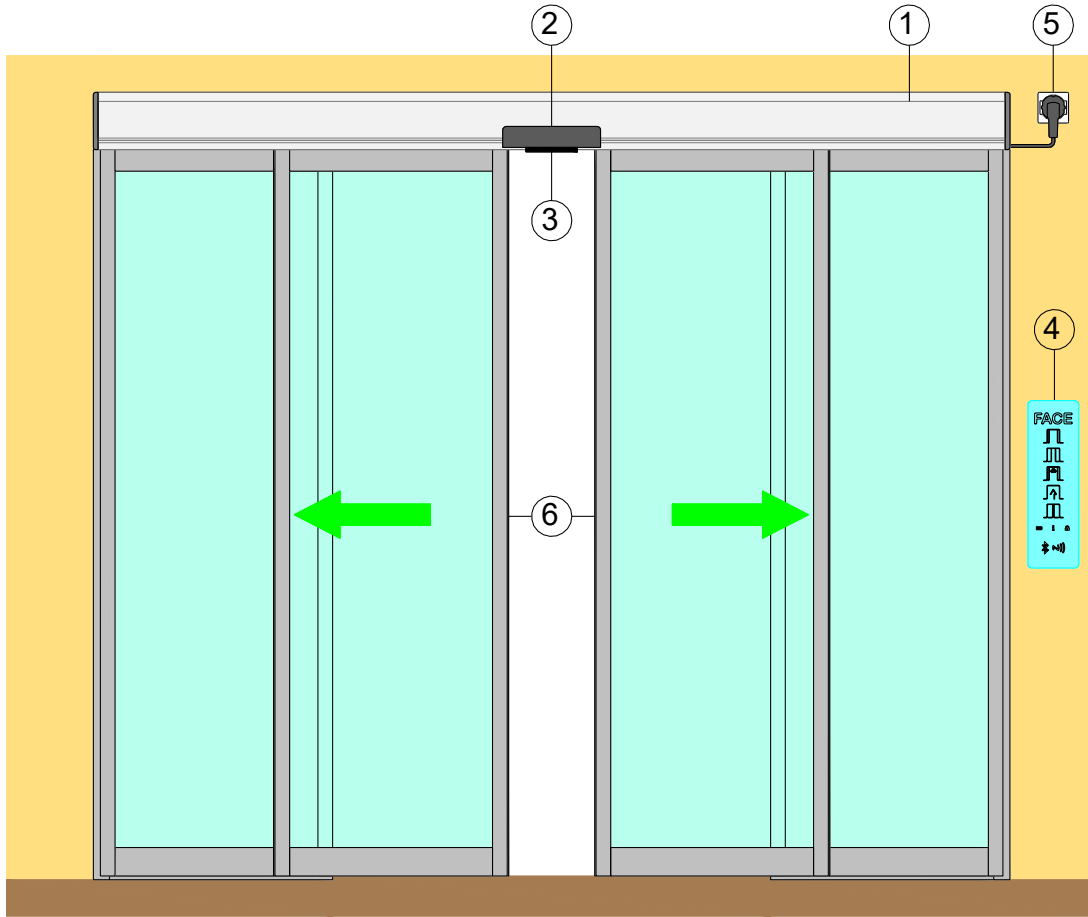

Rif.	Code	Description
1	SL5A220 – SL5A266 SL5E220 – SL5E266	SL5A automation (Advanced) for sliding doors SL5E automation (Emergency) for sliding doors
2	OSD1, OSD3, OSD4, OSD5 OSD4, OSD8	Safety and opening sensor Safety and opening sensor for Emergency exit (Note: To ensure the safety of the doorway, are needed 2 sensors, one on each side)
3	SL5FS	Device for fixing sensors
4	FSD5, FSD6	Electronic function selector
-	SL5BD, SL5BD1 SL5BD2 SLCOD	Battery power device Battery power device for Emergency exit Super capacitor for emergency opening
-	SL5LD SL5SL	Bistable locking device Signal of lock position device
5	-	Power cable for connection of the automation
6	SF30	Sliding door profile system

Note: Components and codes are those most commonly used in systems for automatic sliding doors. The full range of equipment and accessories is also available in the sales list.

The given operating and performance features can only be guaranteed with use of FACE accessories and safety devices.

4. SIZING FOR SLIDING AUTOMATION

The correct sizing of an automatic sliding door depends on the size of the compartment wall and the present encumbrance.

The following tables provide the installation measurements refer to the codes list (considering perimeter profiles and overlaps average), are also indicated the applied formulas to obtain the installation measurements based on the actual dimensions of the wall and frame systems.

To facilitate the calculations and the choice for the ordination of automatic sliding doors, FACE has developed SDC computer program (Sliding Door Configurator), available at www.facespa.it in Download area.

4.1 SIZING FOR 2 SLIDING DOORS

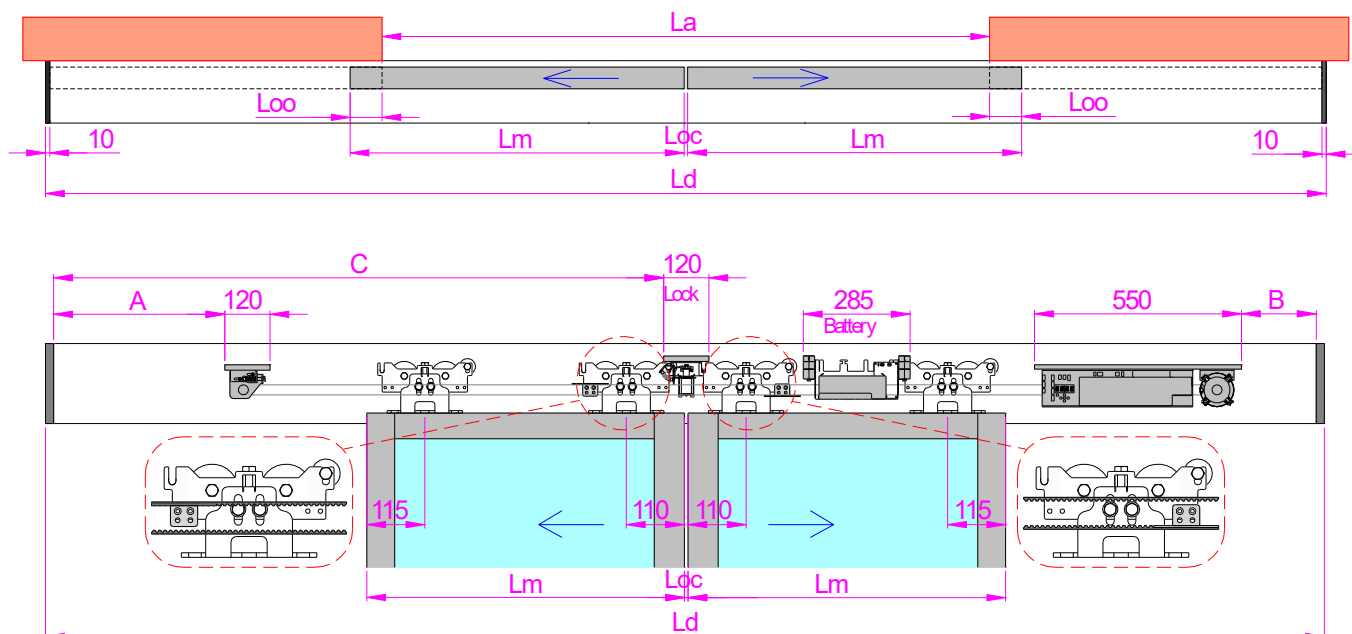

$L_d = L_a + 2L_m + 20$ automation length

$L_a =$ width of the doorway

$L_m = (L_a - L_{oc} + 2L_{oo}) / 2$ leaf width

$L_{oo} =$ overlapping open side door (depending on the type of used frame system)

$L_{oc} =$ overlapping closes side door (depending on the type of used frame system)

Ld	La	Lm	A	B	C	Belt
2.000 mm	940 mm	2 x 520 mm	180 mm	170 mm	930 mm	3,2 m
2.200 mm	1.040 mm	2 x 570 mm	230 mm	220 mm	1.030 mm	3,4 m
2.600 mm	1.240 mm	2 x 670 mm	330 mm	320 mm	1.230 mm	3,8 m
3.000 mm	1.440 mm	2 x 770 mm	430 mm	420 mm	1.430 mm	4,2 m
3.300 mm	1.590 mm	2 x 845 mm	505 mm	495 mm	1.580 mm	4,5 m
3.600 mm	1.740 mm	2 x 920 mm	580 mm	570 mm	1.730 mm	4,8 m
4.000 mm	1.940 mm	2 x 1.020 mm	680 mm	670 mm	1.930 mm	5,2 m
4.400 mm	2.140 mm	2 x 1.120 mm	780 mm	770 mm	2.130 mm	5,6 m
5.000 mm	2.440 mm	2 x 1.270 mm	930 mm	920 mm	2.430 mm	6,2 m
6.600 mm	3.240 mm	2 x 1.670 mm	1.330 mm	1.320 mm	3.230 mm	7,8 m

(Note: Values shown are calculated considering $L_{oo} = 50$ mm e $L_{oc} = 0$ mm)

4.2 SIZING FOR 1 SLIDING DOOR OPENING TO THE RIGHT

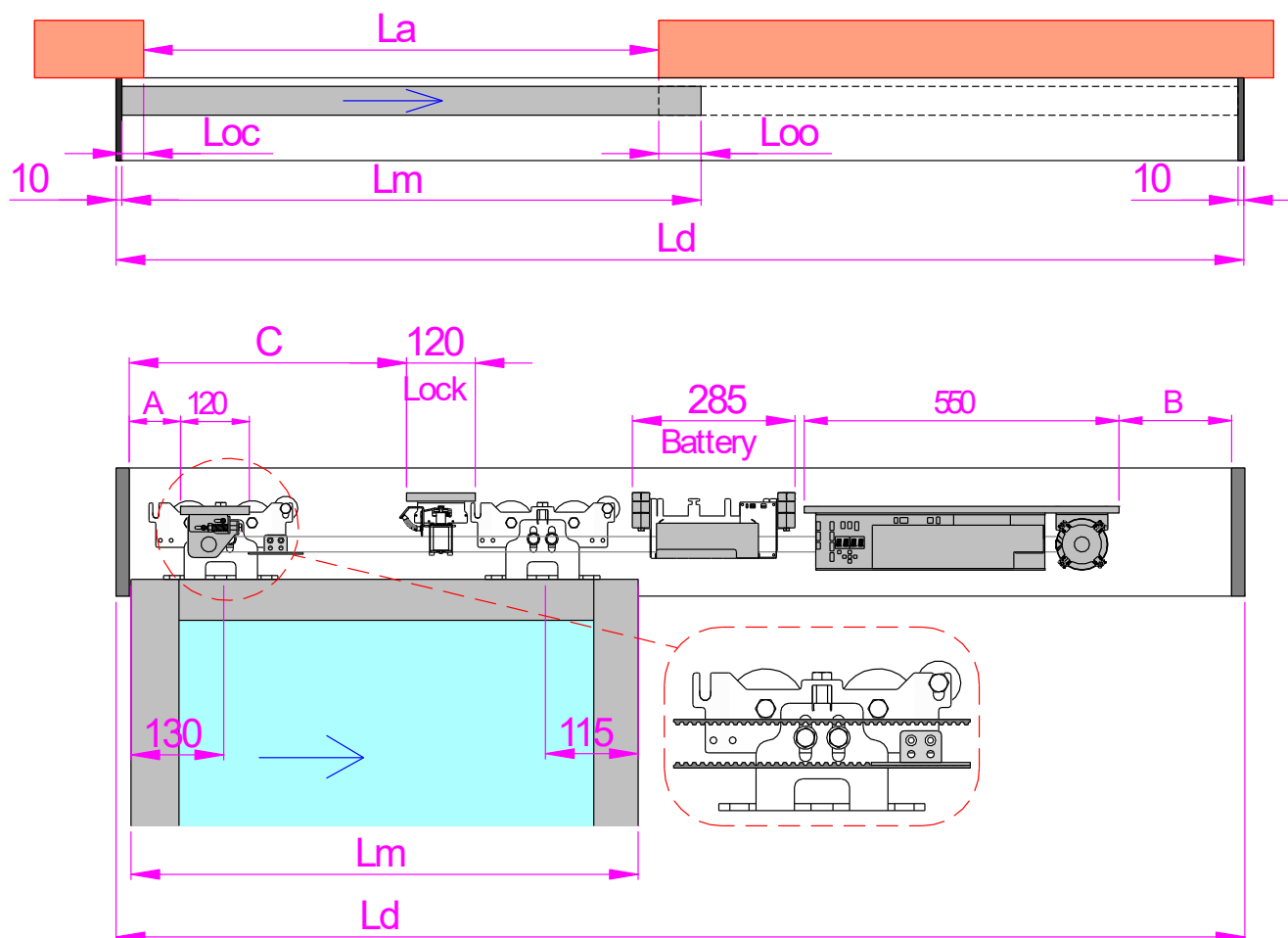

$L_d = L_a + L_m + L_{oc} + 20$ automation length

L_a = width of the doorway

$L_m = L_a + L_{oc} + L_{oo}$ leaf width

L_{oo} = overlapping open side door (depending on the type of used frame system)

L_{oc} = overlapping closes side door (depending on the type of used frame system)

L_d	L_a	L_m	A	B	C	Belt
2.000 mm	915 mm	1.015 mm	45 mm	595 mm	720 mm	2,6 m
2.200 mm	1.015 mm	1.115 mm	45 mm	695 mm	820 mm	2,8 m
2.600 mm	1.215 mm	1.315 mm	45 mm	895 mm	1.020 mm	3,2 m
3.000 mm	1.415 mm	1.515 mm	45 mm	1.095 mm	1.220 mm	3,6 m
3.300 mm	1.565 mm	1.665 mm	45 mm	1.245 mm	1.370 mm	3,9 m
3.600 mm	1.715 mm	1.815 mm	45 mm	1.395 mm	1.520 mm	4,2 m
4.000 mm	1.915 mm	2.015 mm	45 mm	1.595 mm	1.720 mm	4,6 m
4.400 mm	2.115 mm	2.215 mm	45 mm	1.795 mm	1.920 mm	5,0 m
5.000 mm	2.415 mm	2.515 mm	45 mm	2.095 mm	2.220 mm	5,6 m
6.600 mm	3.215 mm	3.315 mm	45 mm	2.895 mm	3.020 mm	7,2 m

(Note: Values shown are calculated considering $L_{oo} = 50$ mm and $L_{oc} = 50$ mm)

4.3 SIZING FOR 1 SLIDING DOOR OPENING TO THE LEFT

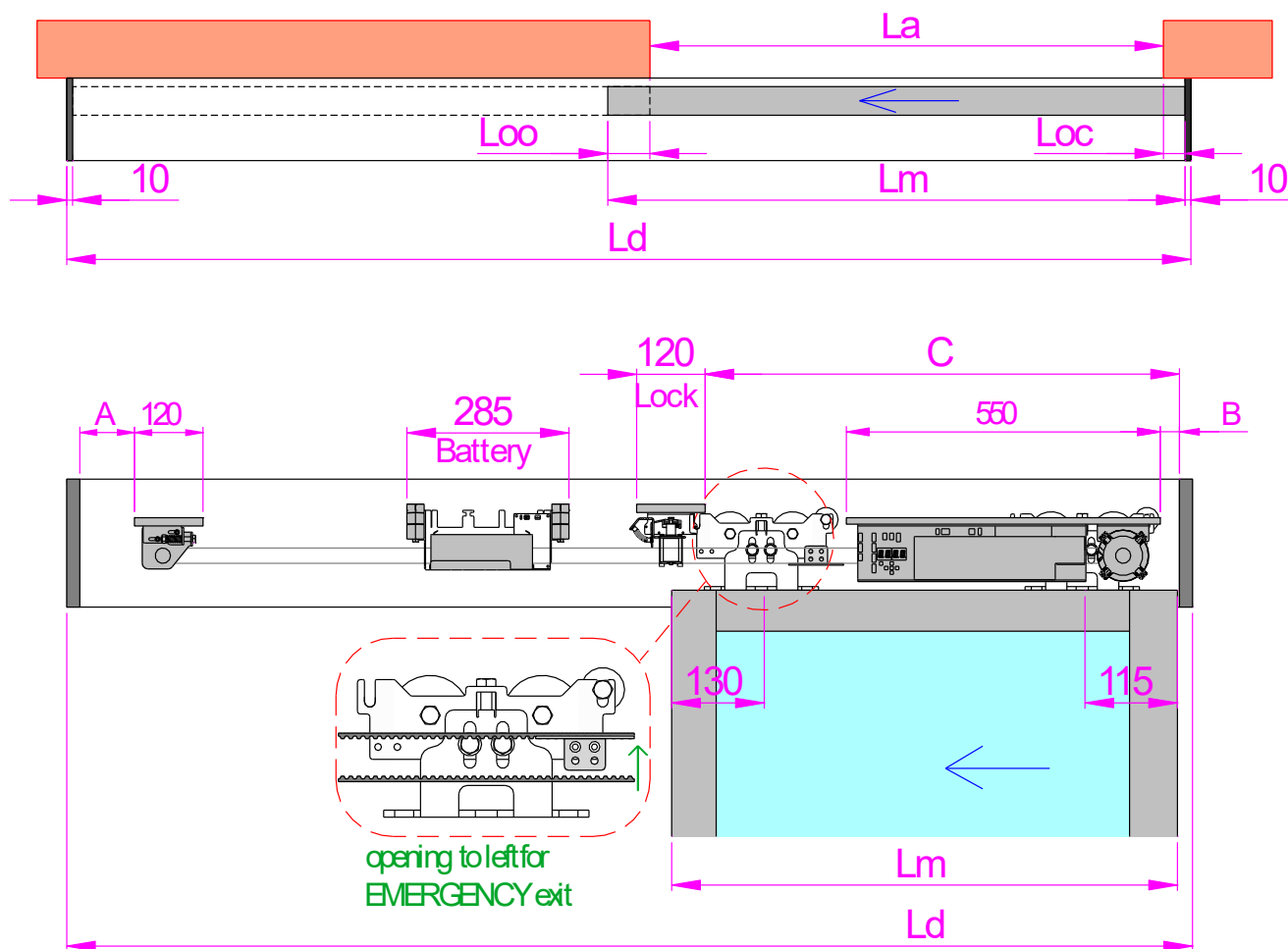

$L_d = L_a + L_m + L_{oc} + 20$ automation length

L_a = width of the doorway

$L_m = L_a + L_{oc} + L_{oo}$ leaf width

L_{oo} = overlapping open side door (depending on the type of used frame system)

L_{oc} = overlapping closes side door (depending on the type of used frame system)

L_d	L_a	L_m	A	B	C	Belt
2.000 mm	915 mm	1.015 mm	45 mm	385 mm	935 mm	3,0 m
2.200 mm	1.015 mm	1.115 mm	45 mm	485 mm	1.035 mm	3,2 m
2.600 mm	1.215 mm	1.315 mm	45 mm	685 mm	1.235 mm	3,6 m
3.000 mm	1.415 mm	1.515 mm	45 mm	885 mm	1.435 mm	4,0 m
3.300 mm	1.565 mm	1.665 mm	45 mm	1.035 mm	1.585 mm	4,3 m
3.600 mm	1.715 mm	1.815 mm	45 mm	1.185 mm	1.735 mm	4,6 m
4.000 mm	1.915 mm	2.015 mm	45 mm	1.385 mm	1.935 mm	5,0 m
4.400 mm	2.115 mm	2.215 mm	45 mm	1.585 mm	2.135 mm	5,4 m
5.000 mm	2.415 mm	2.515 mm	45 mm	1.885 mm	2.435 mm	6,0 m
6.600 mm	3.215 mm	3.315 mm	45 mm	2.685 mm	3.235 mm	7,6 m

(Note: Values shown are calculated considering $L_{oo} = 50$ mm and $L_{oc} = 50$ mm)

4.4 SIZING FOR 4 TELESCOPIC SLIDING LEAVES

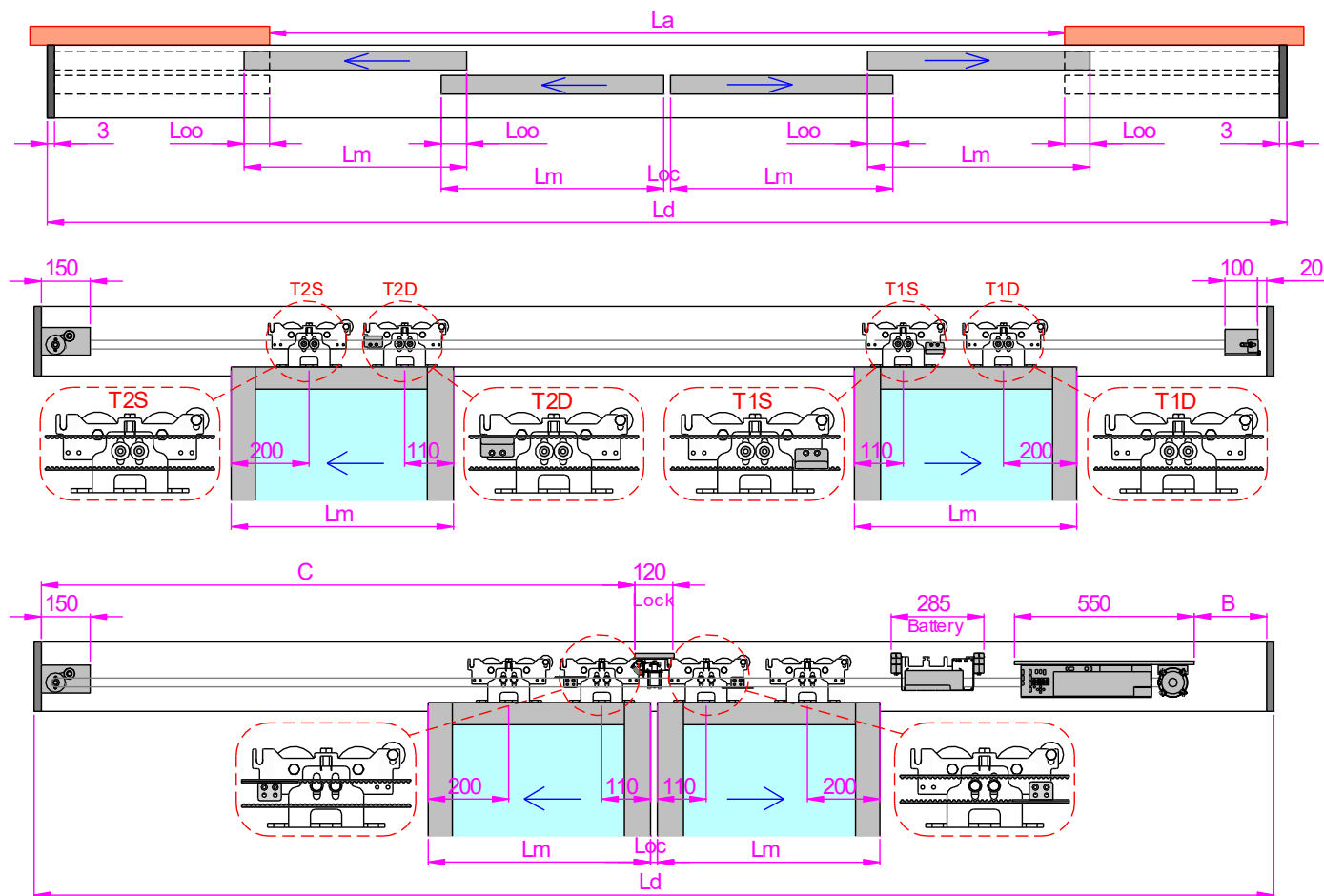

$L_d = L_a + 2L_m + 6$ automation length

L_a = width of the doorway

$L_m = (L_a - L_{oc} + 4L_{oo}) / 4$ leaf width

L_{oo} = overlapping open side door (depending on the type of used frame system)

L_{oc} = overlapping closes side door (depending on the type of used frame system)

Ld	La	Lm	A	B	C	Belt
3.000 mm	1.929 mm	4 x 532 mm	0 mm	187 mm	1.437 mm	11,3 m
3.300 mm	2.129 mm	4 x 582 mm	0 mm	237 mm	1.587 mm	12,3 m
3.600 mm	2.329 mm	4 x 632 mm	0 mm	287 mm	1.737 mm	13,3 m
4.000 mm	2.596 mm	4 x 699 mm	0 mm	354 mm	1.937 mm	14,6 m
4.400 mm	2.862 mm	4 x 766 mm	0 mm	421 mm	2.137 mm	16,0 m
5.000 mm	3.262 mm	4 x 866 mm	0 mm	521 mm	2.437 mm	18,0 m
6.600 mm	4.329 mm	4 x 1.132 mm	0 mm	787 mm	3.237 mm	23,3 m

(Note: Values shown are calculated considering $L_{oo} = 50$ mm and $L_{oc} = 0$ mm)

4.5 SIZING FOR 2 TELESCOPIC SLIDING LEAVES, OPENING TO THE RIGHT

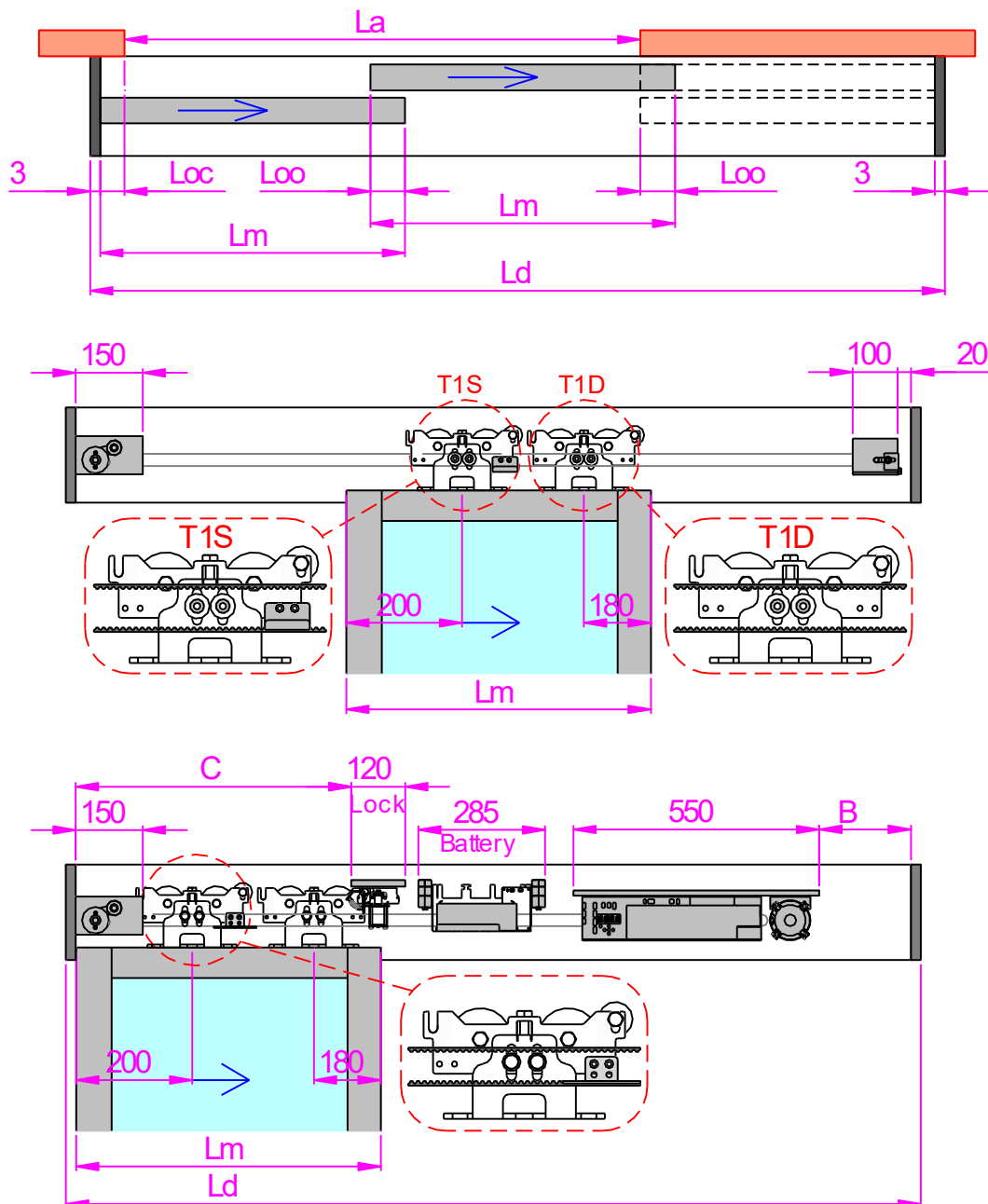

$Ld = La + 2Lm + 6$ automation length

La = width of the doorway

$Lm = (La - Loc + 2Loo) / 2$ leaf width

Loo = overlapping open side door (depending on the type of used frame system)

Loc = overlapping closes side door (depending on the type of used frame system)

Ld	La	Lm	A	B	C	Belt
1.800 mm	1.112 mm	2 x 631 mm	0 mm	196 mm	501 mm	6,5 m
2.000 mm	1.246 mm	2 x 698 mm	0 mm	263 mm	568 mm	7,0 m
2.200 mm	1.379 mm	2 x 765 mm	0 mm	330 mm	635 mm	7,5 m
2.600 mm	1.646 mm	2 x 898 mm	0 mm	463 mm	768 mm	8,6 m
3.000 mm	1.912 mm	2 x 1.031 mm	0 mm	596 mm	901 mm	9,7 m
3.300 mm	2.112 mm	2 x 1.131 mm	0 mm	696 mm	1.001 mm	10,5 m
3.600 mm	2.312 mm	2 x 1.231 mm	0 mm	796 mm	1101 mm	11,3 m
4.000 mm	2.579 mm	2 x 1.365 mm	0 mm	930 mm	1.235 mm	12,3 m
4.400 mm	2.846 mm	2 x 1.498 mm	0 mm	1.063 mm	1.368 mm	13,4 m
5.000 mm	3.246 mm	2 x 1.698 mm	0 mm	1.263 mm	1.568 mm	15,0 m
6.600 mm	4.312 mm	2 x 2.231 mm	0 mm	1.796 mm	2.101 mm	19,3 m

(Note: Values shown are calculated considering $Loo = 50$ mm and $Loc = 50$ mm)

4.6 SIZING FOR 2 TELESCOPIC SLIDING LEAVES, OPENING TO THE LEFT

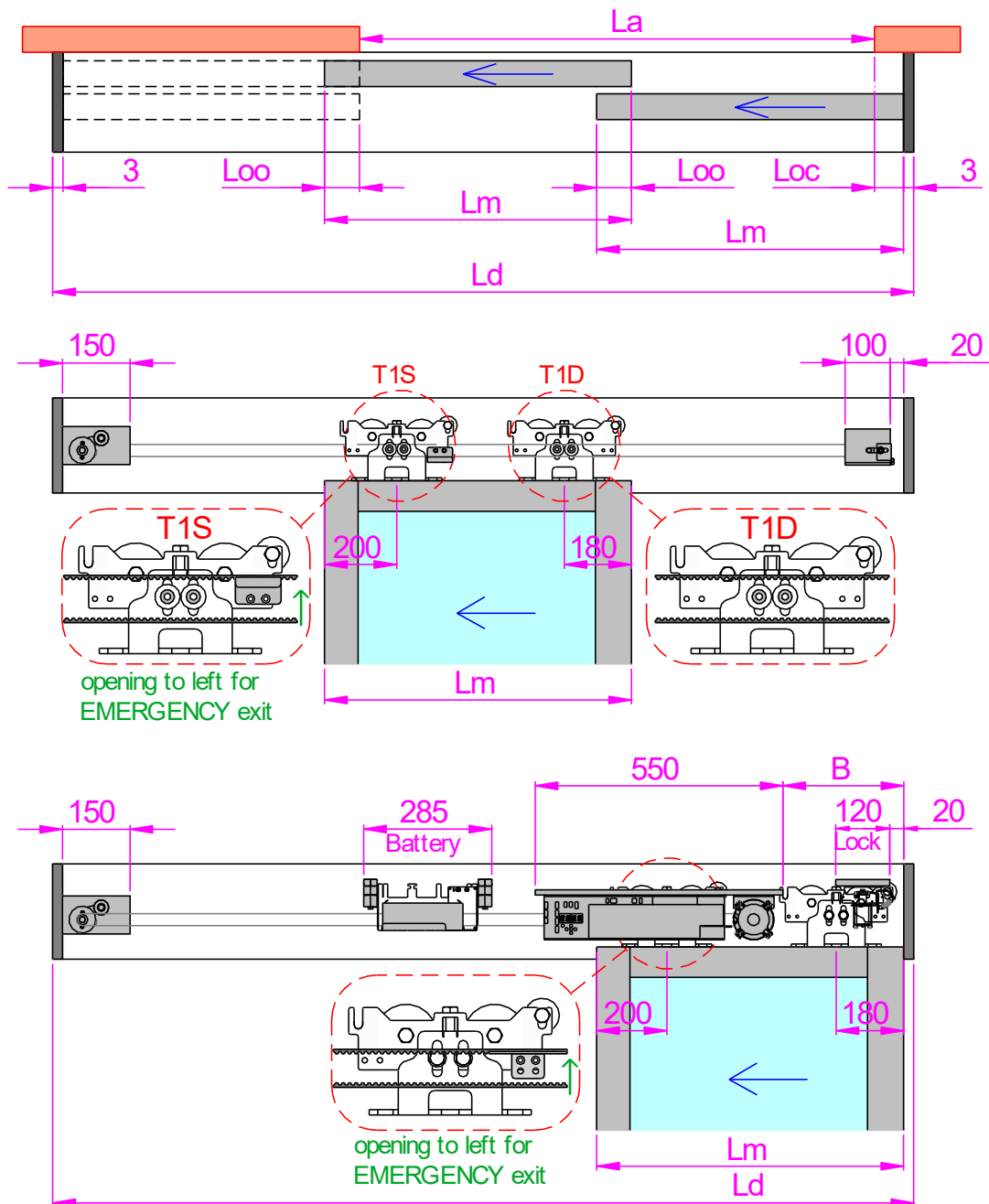

$L_d = L_a + 2L_m + 6$ automation length

L_a = width of the doorway

$L_m = (L_a - L_{oc} + 2L_{oo}) / 2$ leaf width

L_{oo} = overlapping open side door (depending on the type of used frame system)

L_{oc} = overlapping closes side door (depending on the type of used frame system)

L_d	L_a	L_m	A	B	C	Belt
1.800 mm	1.112 mm	2 x 631 mm	0 mm	201 mm	20 mm	6,4 m
2.000 mm	1.246 mm	2 x 698 mm	0 mm	268 mm	20 mm	7,0 m
2.200 mm	1.379 mm	2 x 765 mm	0 mm	335 mm	20 mm	7,5 m
2.600 mm	1.646 mm	2 x 898 mm	0 mm	468 mm	20 mm	8,6 m
3.000 mm	1.912 mm	2 x 1.031 mm	0 mm	601 mm	20 mm	9,6 m
3.300 mm	2.112 mm	2 x 1.131 mm	0 mm	701 mm	20 mm	10,4 m
3.600 mm	2.312 mm	2 x 1.231 mm	0 mm	801 mm	20 mm	11,2 m
4.000 mm	2.579 mm	2 x 1.365 mm	0 mm	935 mm	20 mm	12,3 m
4.400 mm	2.846 mm	2 x 1.498 mm	0 mm	1.068 mm	20 mm	13,4 m
5.000 mm	3.246 mm	2 x 1.698 mm	0 mm	1.268 mm	20 mm	15,0 m
6.600 mm	4.312 mm	2 x 2.231 mm	0 mm	1.801 mm	20 mm	19,2 m

(Note: Values shown are calculated considering $L_{oo} = 50$ mm and $L_{oc} = 50$ mm)

4.7 PROFILES AND GASKET CUTTING MEASURE

All the aluminium profiles and gaskets needed for the realization of the automations must be cut 20 mm shorter than the maximum length of the automation ($L_d - 20$), also including the plastic end caps.

Ref.	Code	Description	SL4
311	K311G66	Drive unit profile raw aluminum 6620 mm	
104	K104A66	Rail profile anodized aluminum 6620 mm	
102	K102G66	Cover profile raw aluminum 6620 mm	
	K102A66	Cover profile anodized aluminum 6620 mm	
107D	K107D	Cover gasket 40 m	
165	K165	Cover-Leaf gasket 40 m	
Ref.	Code	Description	SL5
100	K100A66	Support profile anodized aluminum 6620 mm	
101	K101A66	Drive unit profile anodized aluminum 6620 mm	
104	K104A66	Rail profile anodized aluminum 6620 mm	
102	K102G66	Cover profile raw aluminum 6620 mm	
	K102A66	Cover profile anodized aluminum 6620 mm	
107B	K107B	Drive unit gasket 40 m	
107C	K107C	Support gasket 40 m	
107A	K107A	Rail gasket 40 m	
107D	K107D	Cover gasket 40 m	
165	K165	Cover-Leaf gasket 40 m	
Ref.	Code	Description	SL6
781	K781A66	Drive unit profile anodized aluminum 6620 mm	
104	K104A66	Rail profile anodized aluminum 6620 mm	
102	K102G66	Cover profile raw aluminum 6620 mm	
	K102A66	Cover profile anodized aluminum 6620 mm	
107A	K107A	Rail gasket 40 m	
107D	K107D	Cover gasket 40 m	
165	K165	Cover-Leaf gasket 40 m	
Ref.	Code	Description	SLT
505	K505G66	Drive unit profile raw aluminum 6620 mm	
507	K507A66	Rail profile anodized aluminum 6620 mm	
104	K104A66	Rail profile anodized aluminum 6620 mm	
102	K102G66	Cover profile raw aluminum 6620 mm	
	K102A66	Cover profile anodized aluminum 6620 mm	
107D	K107D	Cover gasket 40 m	
165	K165	Cover-Leaf gasket 40 m	

All the aluminium profiles and gaskets needed for the realization of the telescopic automations must be cut 6 mm shorter than the maximum length of the automation ($L_d - 6$), also including the end caps.

Only the [507] rail profile must be cut $L_d - 130$ length.

4.8 VERTICAL DOOR DIMENSION

The automations are compatible with the majority of frame in trade.

The formulas are for the calculation of the vertical measure fastening automations (Hd), and for the calculation of the height of sliding door (Hm).

Note: make sure that there is at least 20 mm above the automation, to allow the opening of the cover.

- You can make sliding leaves by means of aluminum profiles SF30 series, as indicated in the figure.

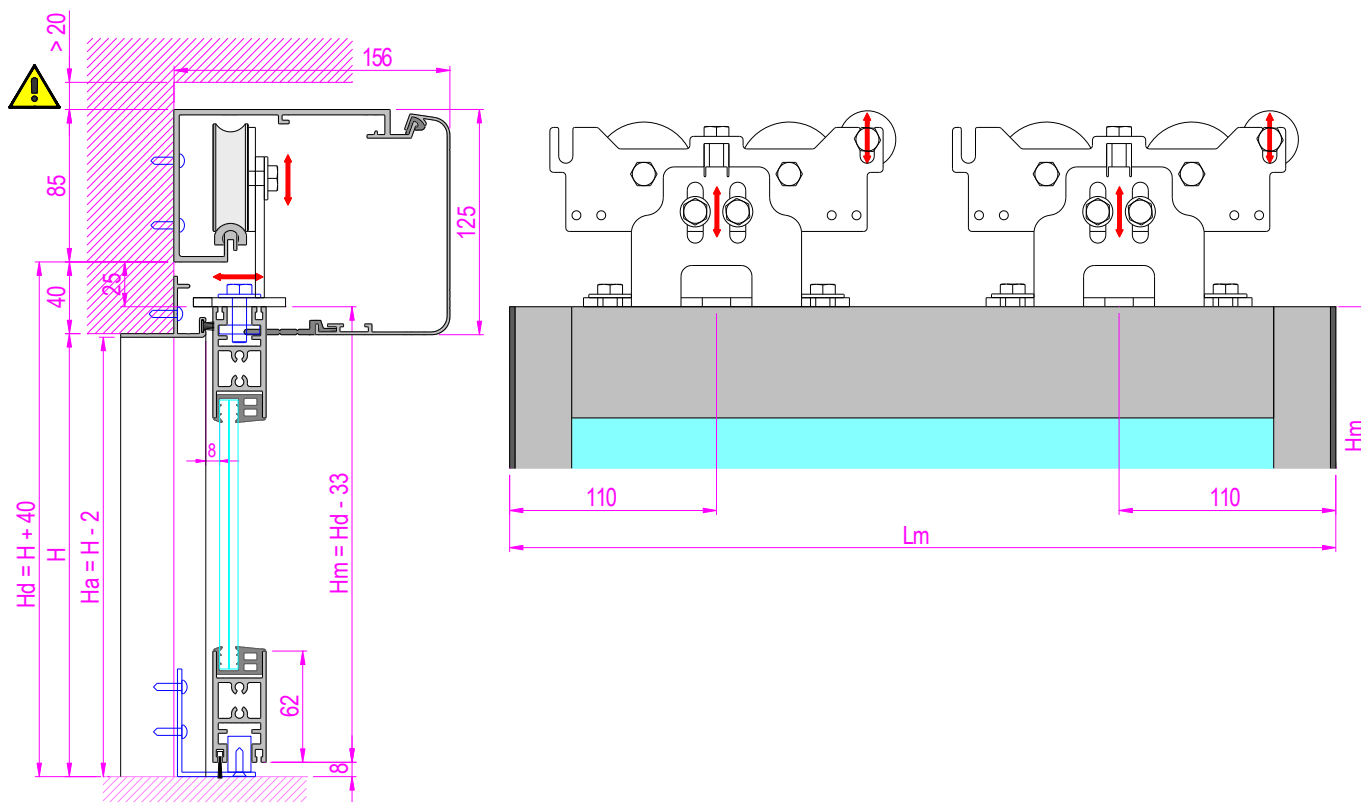

- You can make telescopic sliding leaves by means of aluminum profiles SF30 series, as indicated in the figure.

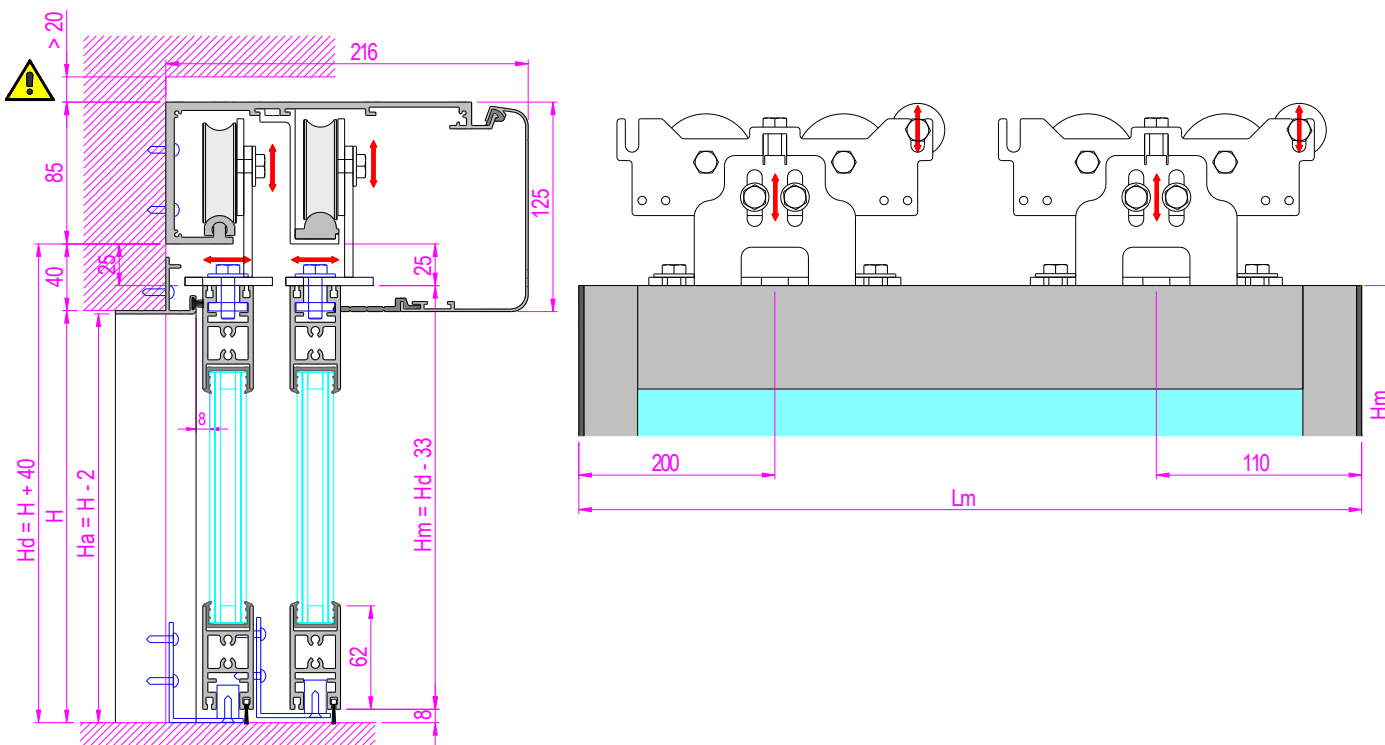

- To facilitate the horizontal adjustment of the leaves you can use the fixing door profile and the floor guide kit, as indicated in the figure.

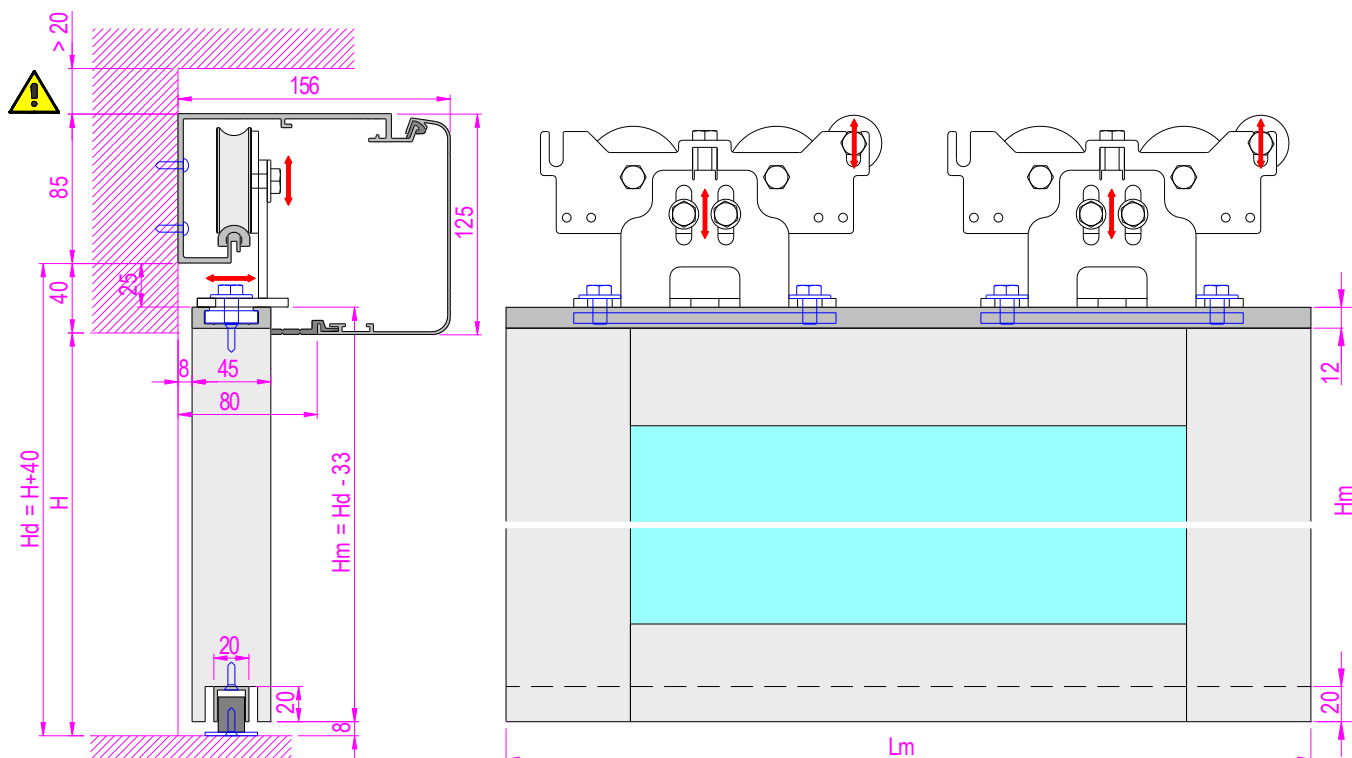

- To facilitate the horizontal adjustment of the telescopic leaves (with 45-50 mm thickness) you can use the fixing door profile and the floor guide kits, as indicated in the figure.

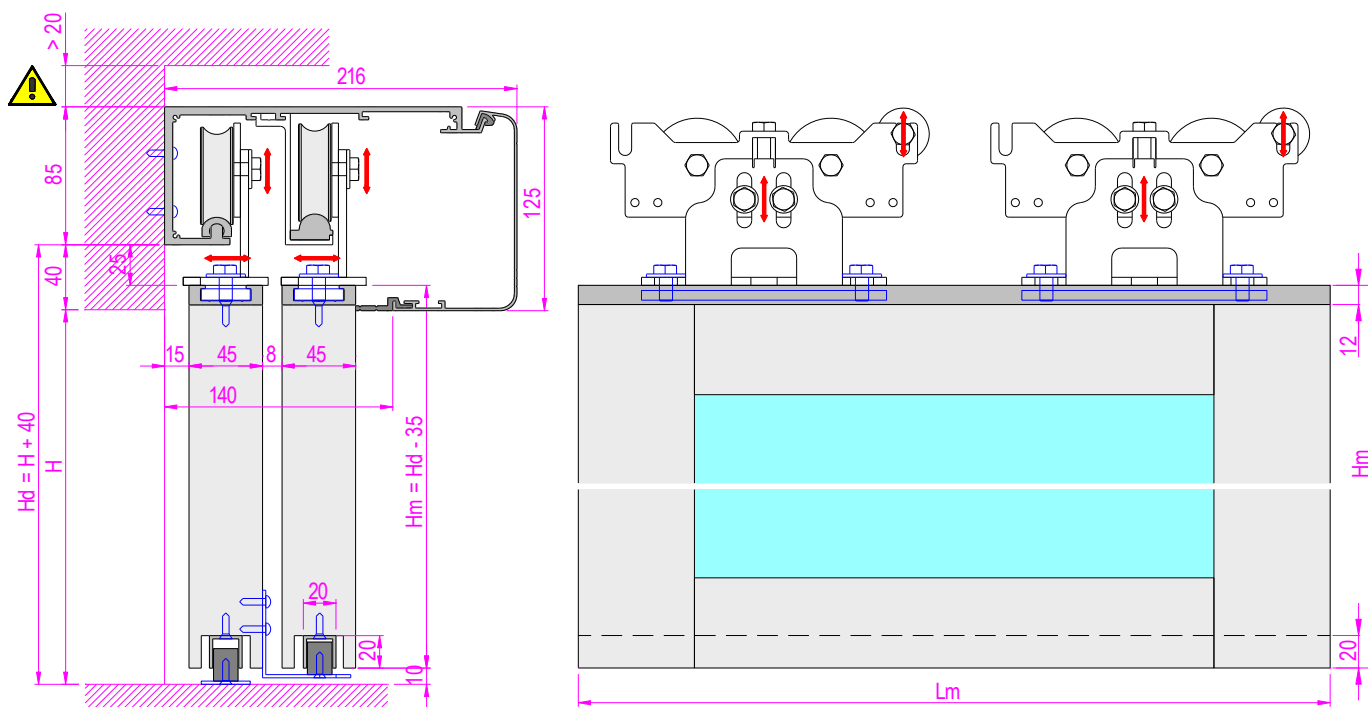

- To make doors with glass doors, you can use the fixing profile for glass door, as indicated in the figure.

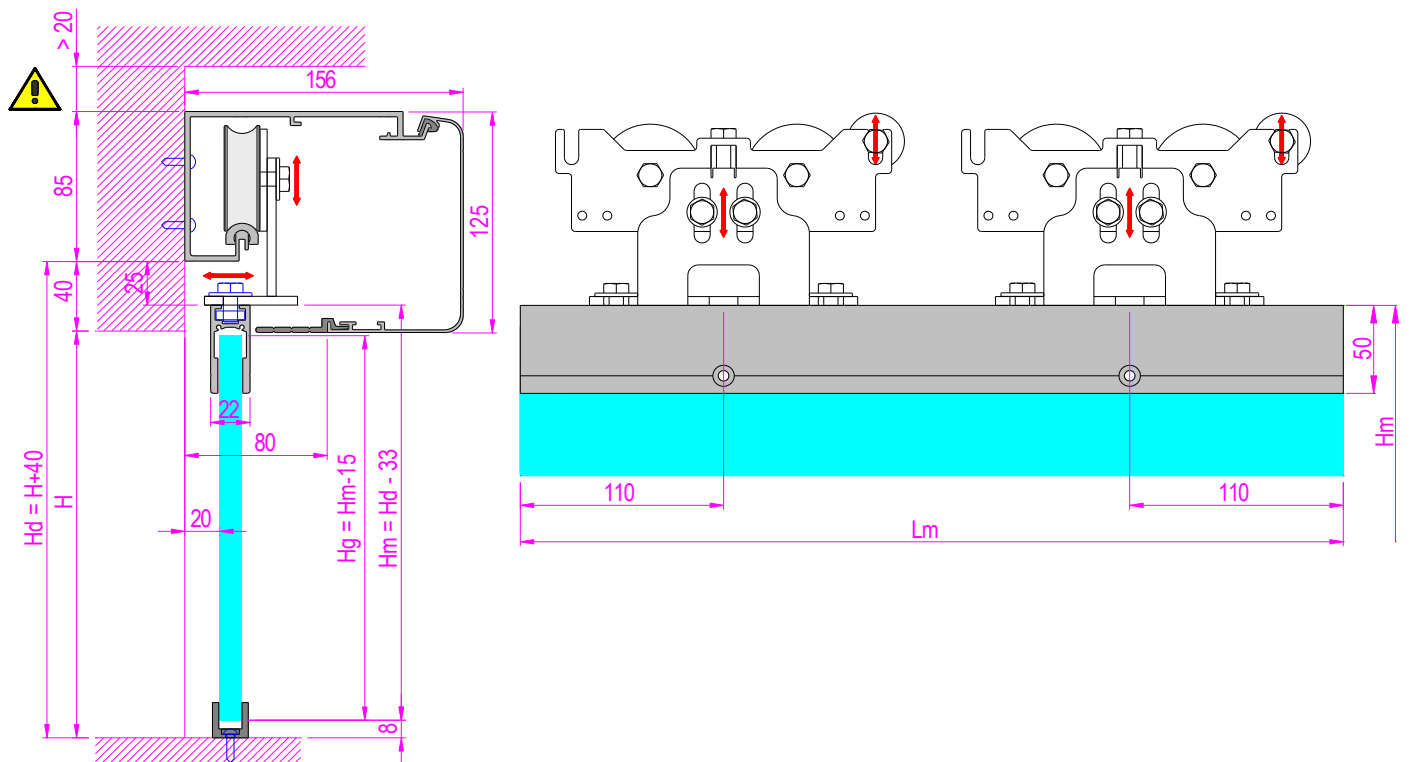

- To make telescopic doors with glass doors, you can use the fixing profile for glass door, as indicated in the figure.

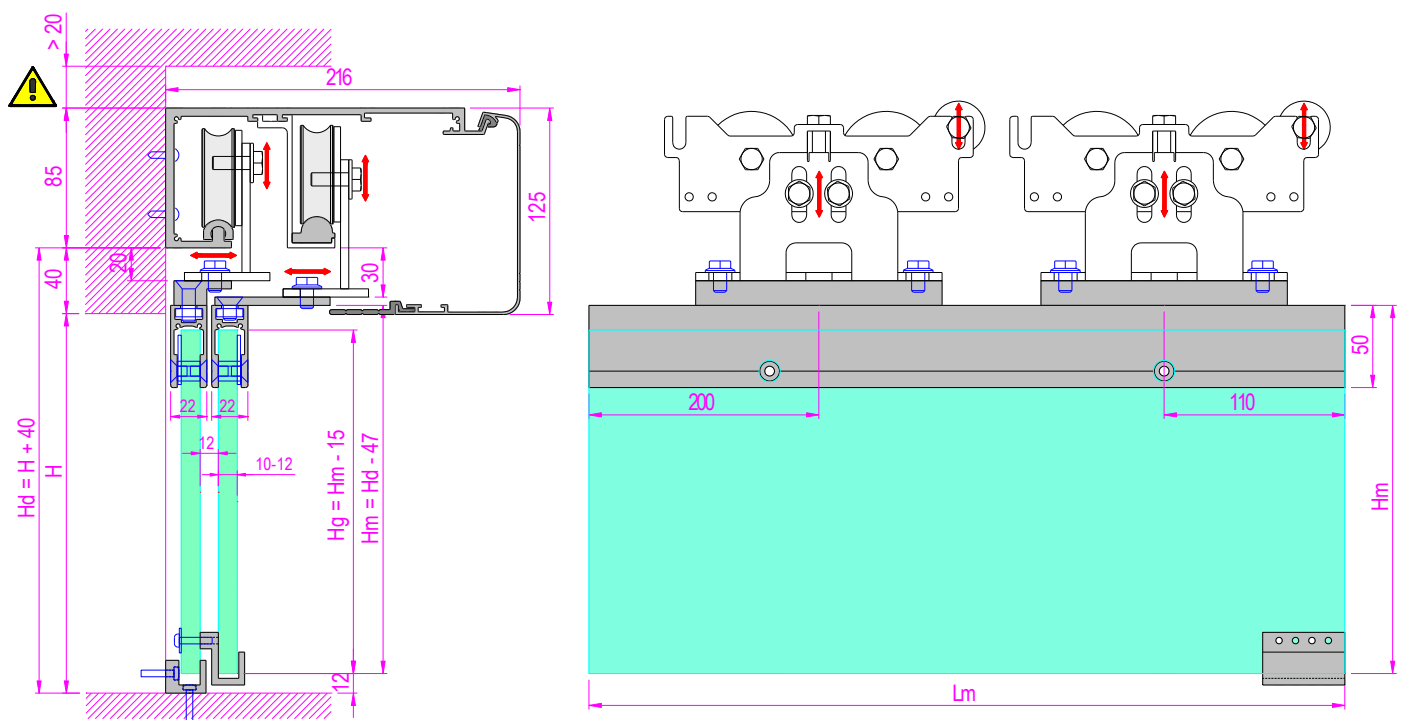





5. ASSEMBLY PROCEDURE OF THE AUTOMATION

The automations should be assembled by qualified personnel, and can be done at the factory or directly at the place of installation of the door. After size cutting all aluminium profiles and gaskets (as indicated in the chapter 4.7), we proceed with the automation and internal components assembly.

For assembly operations, in addition to the usual generic tools such as scissors, pliers, screwdrivers, only two tools are used:

- Combination spanner 13mm
- Allen key 4 mm

The tightening torque of the screws is shown in the following table.

Screw type		Torque	Ref.
	M8 x 16 mm	1,5 Nm	5.4 – 5.11
	4,8 x 13 mm	0,5 Nm	5.10
	M5 x 12 mm	5 Nm	end cap
	2,9 x 13 mm	1 Nm	end cap



5.1 (SL4) ASSEMBLY OF AUTOMATION

- Insert the rail profile in the drive unit profile.
- Insert the cover gasket on the drive unit profile.
- Insert the right and the left end caps on the drive unit profile, and secure them with the screws.

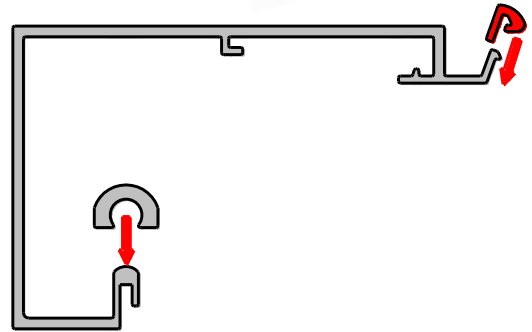

5.2 (SL5) ASSEMBLY OF AUTOMATION

- Insert the gasket in the rail profile.
- Thread by slide, the profile rail and gasket in the drive unit profile.
- Insert the support gasket in the upper part of the support profile.
- Insert the drive unit gasket at the bottom of the support profile.
- Attach the drive unit profile on the support profile.
- Insert the cover gasket on the drive unit profile.
- Insert the right and the left end caps on profiles (already assembled), and secure them with the screws.

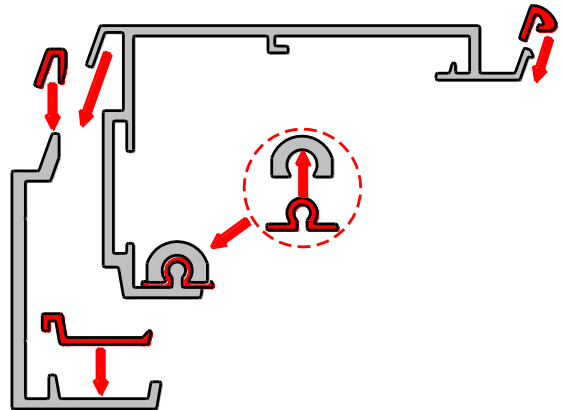

- Connect the support profile to the ground using the earth cable supplied.

Secure the earth cable by connecting it to the right end cap screw and to the mechanical stop bracket, as shown in the figure.

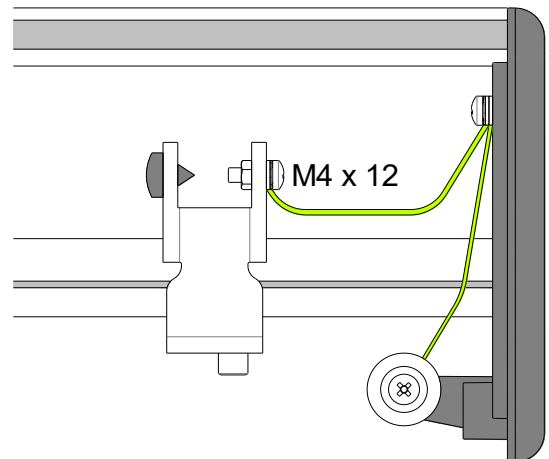

5.3 (SL6) ASSEMBLY OF AUTOMATION

- Insert the gasket rail in the profile rail.
- Thread by slide, the profile rail and seal in the drive unit profile.
- Insert the cover gasket on the drive unit profile.
- Insert the right and the left end caps on the drive unit profile, and secure them with the screws.

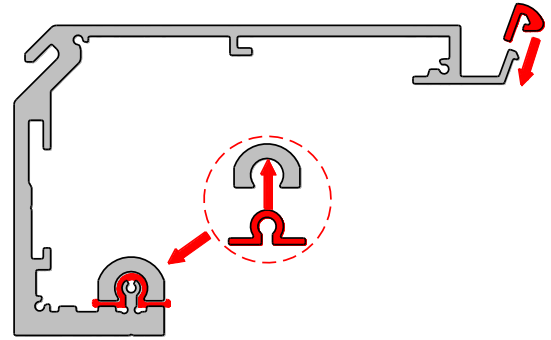

5.4 Secure by front hooking the drive unit on the drive unit profile, placed at a maximum B (as shown in Chapter 4), and secure it with the screws (Note: if there is space, it's better to reduce measure B few centimetres).

CAUTION: If the front hooking of the drive unit is difficult, check the following:

- Check that the 3 screws of the drive unit are completely loose, so as not to hinder the hooking;
- ONLY IF NECESSARY, remove the electronic control.

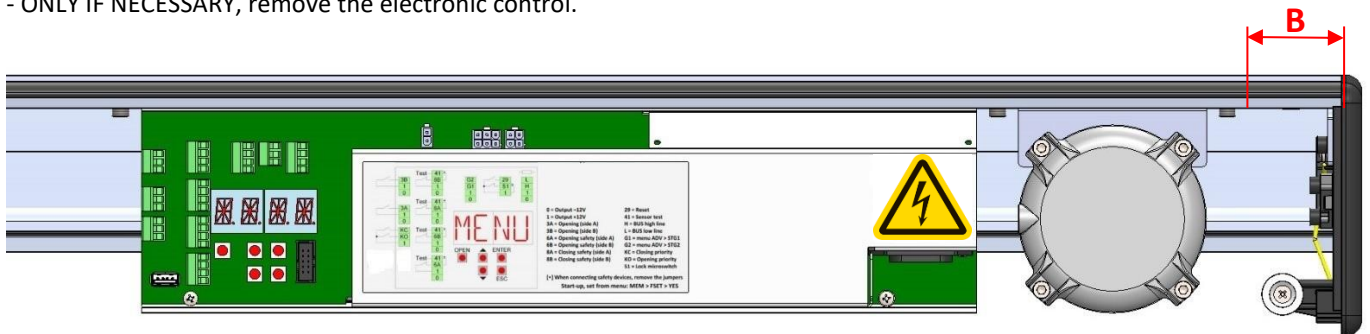

BIG DRIVE UNIT

- Loosen the two screws (a), secure by front hooking the drive unit on the drive unit profile, placed at a maximum B.
- Tighten the two screws (a).
- Adjust the correct belt tension using the two screws (b).

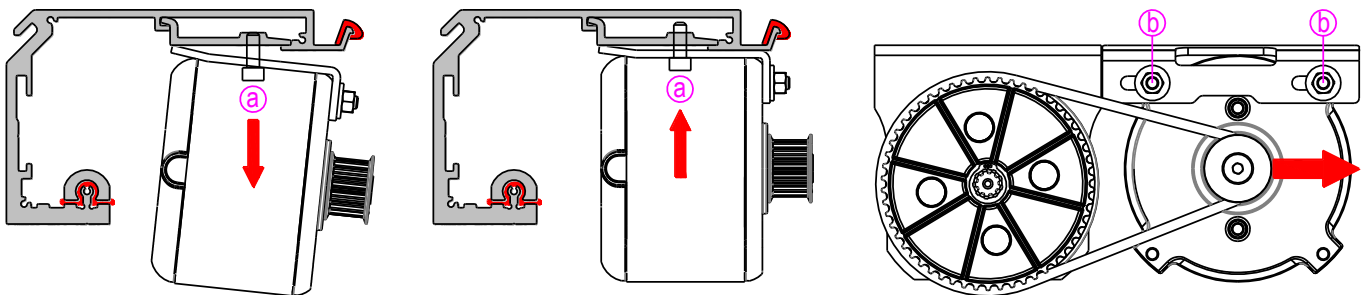

5.5 Secure by front hooking the transmission unit on the drive unit profile, place it to maximum A (as described in Chapter 4), and secure it with the screws.

Note: if there is space, it's better to reduce measure A few centimetres.

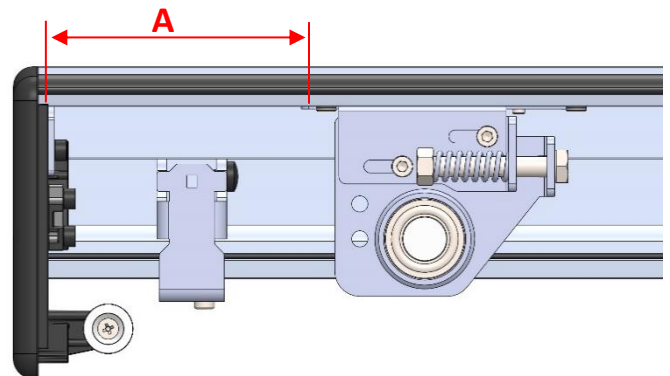

5.6 Insert the carriages in front on the drive unit profile.
The carriages should be positioned as shown in Chapter 4.

5.7 Insert the two front brackets mechanical stop near the end caps, and secure with the screws.

In the case of 2-leaves automation, add a mechanical stop bracket to the center.

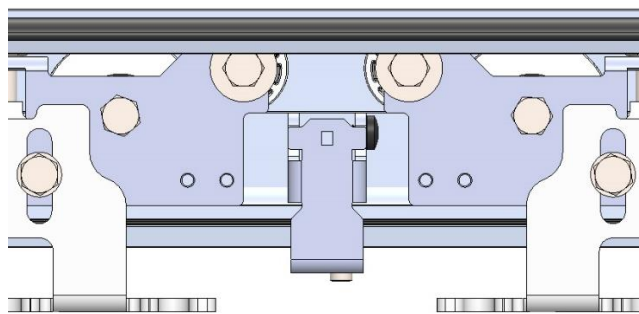

5.8 Insert the belt in the pulley motor drive unit, slide it and pass it around the transmission unit and fix to carriage with the proper springs (see the belt attack position, as shown in Chapter 4).

5.9 Fix by front hooking the support brackets for electric cables on the drive unit profile. The brackets support cables should be positioned along the path of the electrical cables in order to prevent it from interfering with the running of the carriages.

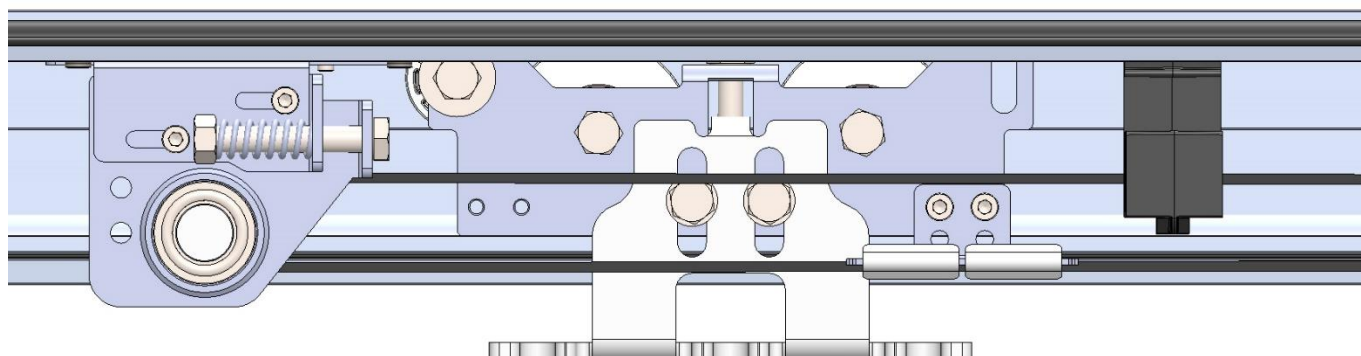

5.10 AUTOMATION CLOSING

- Screw (0,5 Nm) the brackets for the magnetic coupling on the cover profile 15 mm from the edge (as shown in figure).
- If you need, insert the cover-leaf gasket on the cover profile to reduce the slit bottom of automation.
- Hang the cover profile to the drive unit profile. The drive unit profile is kept closed by magnets on the end caps.

Note: To avoid that the cover can be opened without the use of a tool, it is necessary to make two 5 mm holes in diameter at the ends of the cover profile, as shown in the figure, and fix the cover with the screws 4,8 x13 in provided.

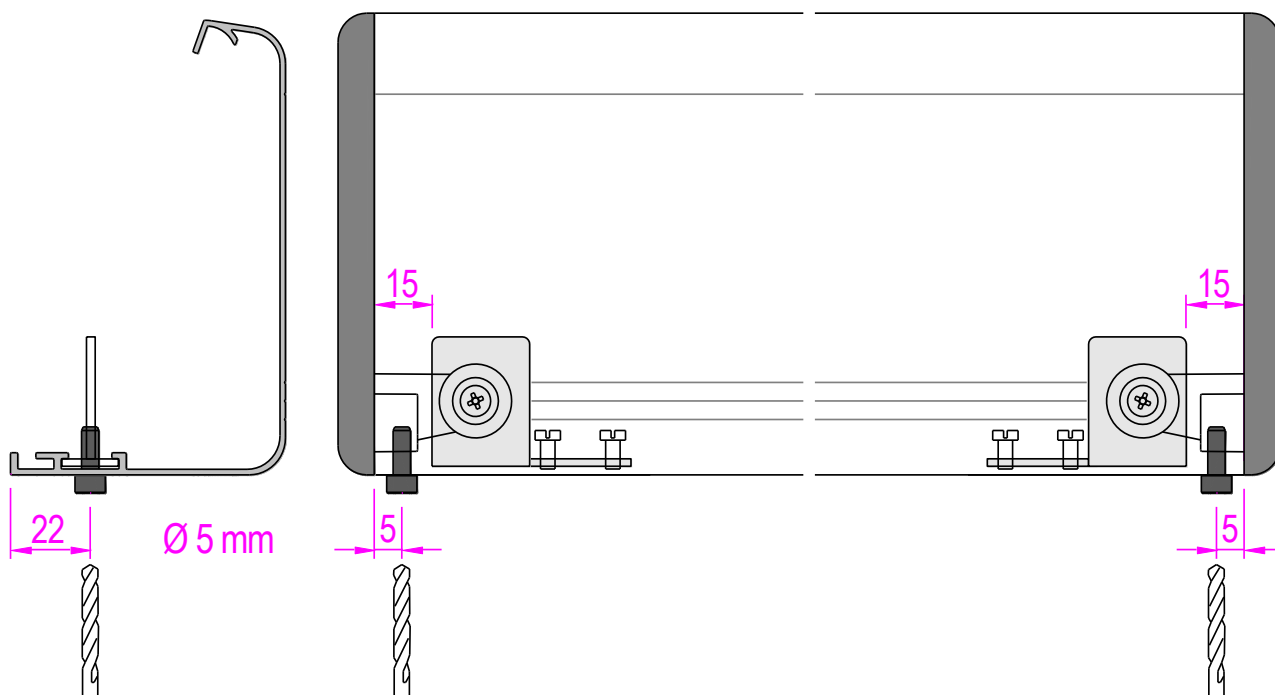

5.11 ASSEMBLY OF TELESCOPIC AUTOMATION

- Insert the rail profile [104] in the drive unit profile [505].
- Fix the guide support brackets [602] into the drive unit profile [505], about every 500 mm.
- Insert the rail profile [507] on the guide support brackets [602], and fix with the special mechanical limit switches.
- Insert the cover gasket [107D] on the drive unit profile [505].
- Insert the right and the left end caps on the drive unit profile [505], and secure them with the screws.

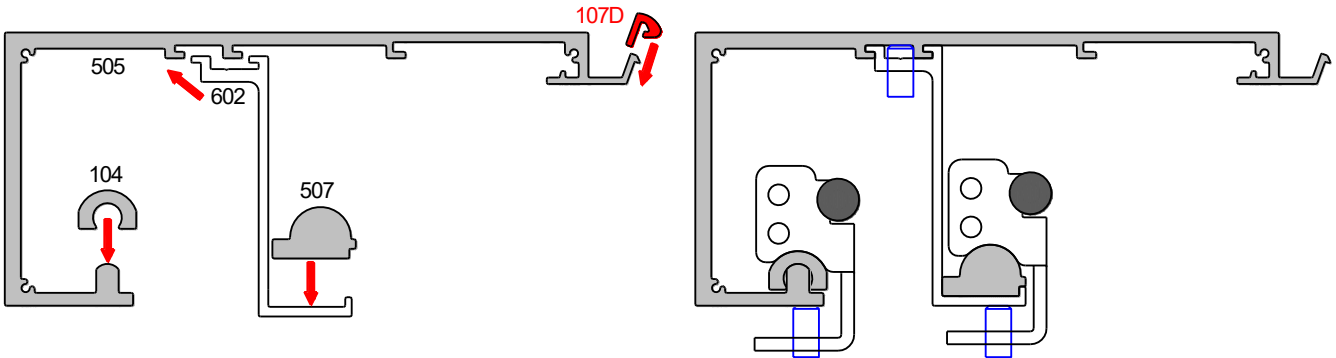

- fix the double pulley transmission to the left side of automation;
- fix the transmission unit to the right side of automation, 20 mm from the end;
- link the double pulley transmission and the transmission unit to the right side of automation, through the transmission belt, and fix the belt to the carriage using the proper bracket (see the belt attack position, as shown in Chapter 4).

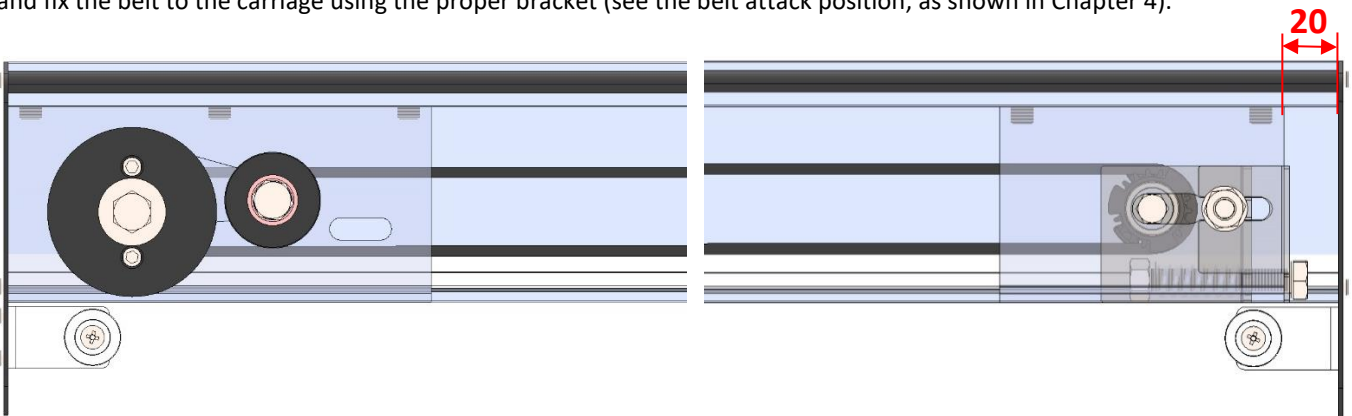

- Insert the belt in the pulley motor drive unit, slide it and pass it around the double pulley transmission and fix to carriage with the proper springs (see the belt attack position, as shown in Chapter 4).

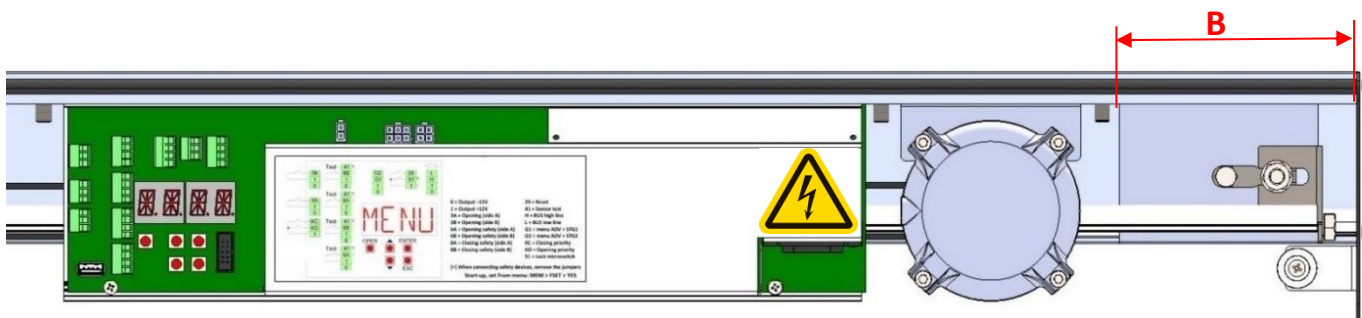
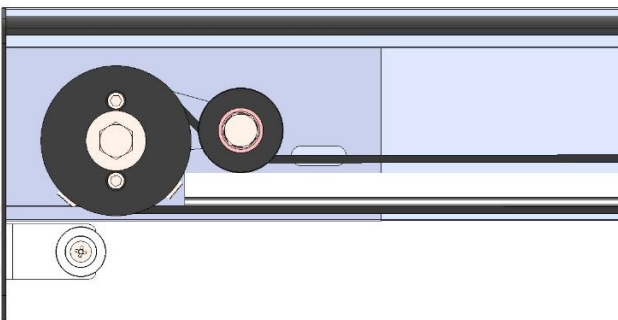

6. AUTOMATION AND SLIDING DOORS INSTALLATION

The installation of an automatic sliding door, carried out by qualified personnel, can take place only after the on-site inspection (described in section 1), and after the design and construction of the system frame and automation (described in section 4).

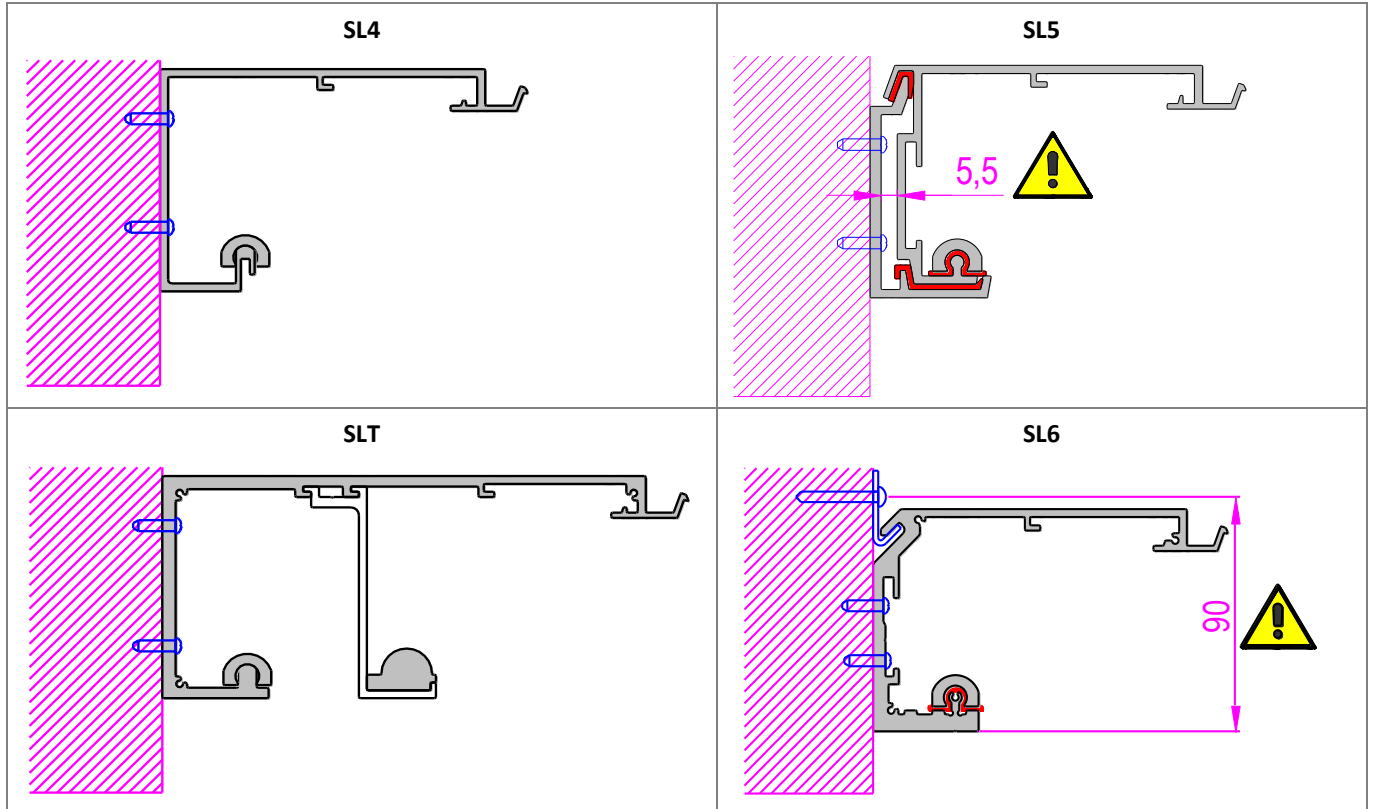

6.1 Wall mounting of drive unit profile.

Chapter 4.8 shows the vertical mounting dimensions of automations.

The automations are compatible with the majority of frame systems in trade.

Fixing of the drive unit profile to the wall must be safe and suitable for the weight of the doors. Distribute the fixing points every 500 to 800 mm (or 300÷500 mm for heavy doors) along the present lines on the aluminium profile, using suitable plugs and screws, not supplied by us.

Note: the wall must be straight and smooth, otherwise you have to prepare adequate thickness or iron plates on which to secure the drive unit profile, to allow for proper leveling.

6.2 Must be prepared and executed the channel and the holes for the passage of the power cord and cables for connecting the control and safety devices (sensors, function selector, buttons, etc.).

6.3 Adjust the tension of the belt with the transmission unit as shown in the figure:

- Manually push to left the transmission unit, so as to tension the belt, and attach it to the drive unit profile by screws,
- Loosen the screws [a],
- Tighten the screw [b] and compress the spring until 18 mm (always check manually, the belt tension is not too tight or too loose),
- Lock the adjustment of the belt tension by tightening the screws [a].

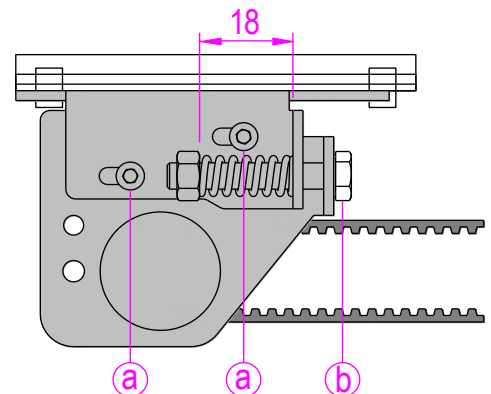

6.4 Passage of electrical cables automation.

In the upper part of the end caps [4] is prepared the area to be drilled for the passage of electric cables. Also inside of the caps there is a terminal block for electrical cables. The route of the cables inside the automation is supported and guided by support brackets cable, as indicated in Section 5.

6.5 Secure the sliding doors to the carriages by M8 screws, as shown in Chapter 4 (for heavy doors, fix the leaf in the 3 points available of the carriage).

- Bring the doors to the closed position and make height adjustments using the screws [b] and [c]. Carry out the depth adjustment using the screws [a].

- Adjust the position of the upper wheels [d] in order to avoid the output of the carriage from the rail profile. Move the leaves by hand throughout the run and make sure it moves freely and without friction and that all the wheels touch the rail profile.

Note: if the sliding door has a break-out system, it is necessary to add the second upper wheel [e] on each carriage, as indicated in the figure, to avoid that very strong pushing of leaf causes the output of the carriage from the rail profile (in KBS1E break-out kit, the wheels [e] are already included). If break-out systems of other brands are used, it is necessary to buy the upper wheels [e] code 5140.

- Make sure that the bottom of the doors is properly guided by the floor runner.

- Adjust the position of the brackets with a mechanical stop to limit the travel of the doors in the desired locations.

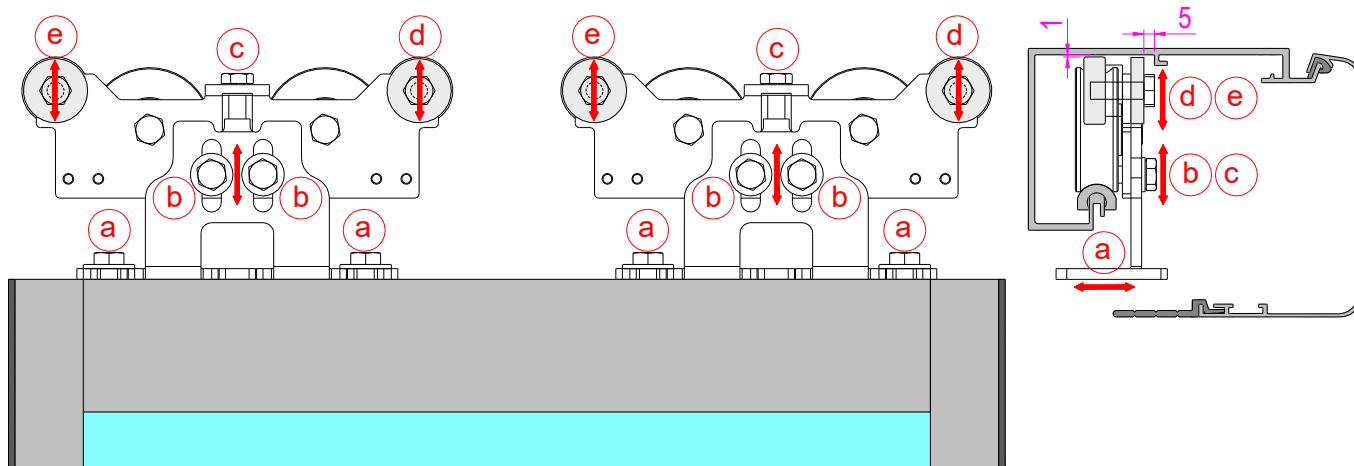

6.6 Adjustment of the telescopic doors

- Adjust the tension of the belt of the "slow" doors using the transmission unit on the right side, as shown in the figure:

loosen the nut [a],

tighten the screw [b], so as to tension the belt (always check manually, the belt tension is not too tight or too loose),

lock the adjustment of the belt tension by tightening the nut [a].

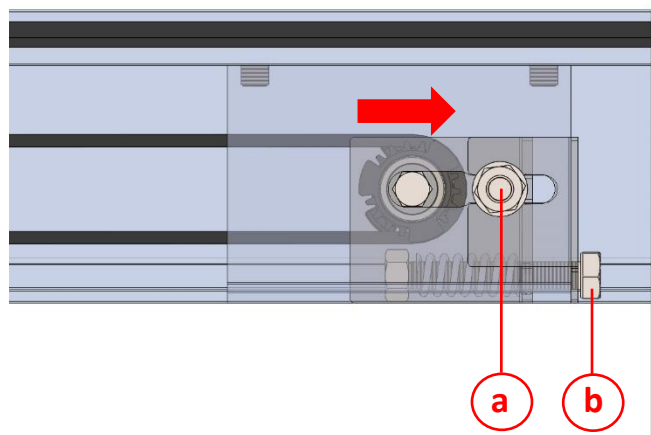

- Adjust the tension of the belt of the "fast" doors using the double pulley transmission on the left side, as shown in the figure:

loosen the screws [c],

push down the tensioner pulley so as to tension the belt (always check manually, the belt tension is not too tight or too loose),

lock the adjustment of the belt tension by tightening the screws [c].

- To facilitate the adjustment of the telescopic doors, you can move independently the "slow" leaves and the "fast" leaves, loosening the screws [d] of the double pulley transmission. After adjustments, move the doors in the opening position and tighten the screws [d].

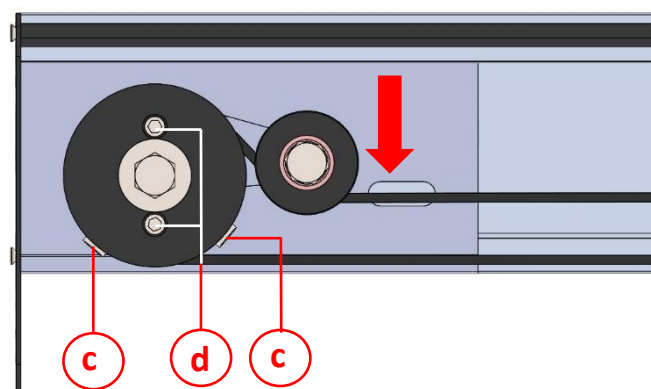

6.7 AUTOMATION CLOSING

See chapter 5.10.

7. ELECTRICAL CONNECTIONS

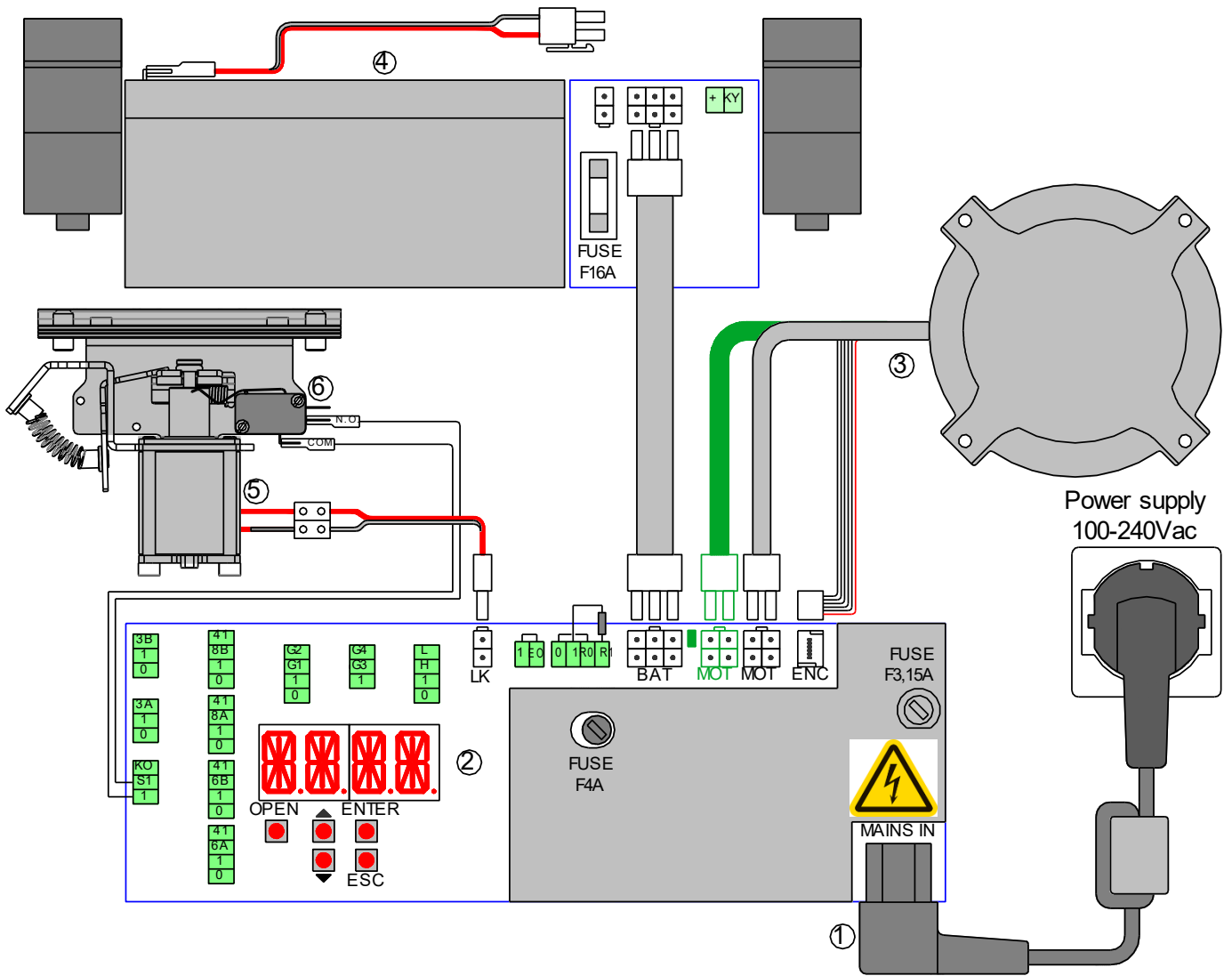

Ref.	Code	Terminals	Description
1	3EW250V	MAINS IN	Cable for connection to the power supply.
2	5CB01 5CB01E		Electronic control Electronic control for Emergency exit
3	5B90SL 5B90E	MOT MOT ENC	Brushless motor Brushless motor for Emergency exit Angular sensor
4	SL5BD SL5BD2 SLCOD	BAT BAT BAT	Battery power device Battery power device for Emergency exit Super capacitor for emergency opening
5	SL5LD	LK	Locking device
6	SL5SL	1-S1	Signaling lock position device for Emergency exit

7.1 GENERAL SAFETY ELECTRICAL PRECAUTIONS

Installation, electrical connections and adjustments must be completed in conformity with Good Working Methods and with regulations in force.

Before making power connections, check that the rating corresponds to that of the mains supply. A multipolar disconnection switch with a contact opening gap of at least 3 mm must be included in the mains supply. This switch must be protected from unauthorized activations.

Check that, upstream of the electrical installation, an adequate residual current circuit breaker and an overcurrent cut out are fitted.

Connect the automation to an effective earthing system carried out as indicated by current safety regulations.

During installation, maintenance and repair operations, cut off the power supply before opening the cover to access the electrical parts. To handle electronic parts, wear earthed antistatic conductive bracelets.

FACE declines all responsibility in the event of components which are not compatible with the safe and correct operation of the product.

For repairs or replacements of products only original spare parts must be used.

7.2 POWER SUPPLY ELECTRICAL CONNECTION

Use the supplied cable for connection to electricity.

The power cable can be connected to an electric plug (not supplied by us), arranged near the end cap of the automation.

Drill a hole in the end cap area prepared, route the power cord and secure it (1 Nm) inside the end cap through the cable tie.

Note: file off the edge of the aluminum, so as to eliminate sharp edges that might damage the power cable.



In case there isn't a socket near the automation, perform the connection to the power supply in the following manner: drill the aluminum profile in the upper part or in the rear wall fixing, protect the passage of the power cord through membrane grommets or cable glands (not supplied by us) to eliminate sharp edges that might damage the power cable, and connect the cable to the power supply.

The connection to the mains supply in the outer portion automation, should be an independent channel, separated from the connections to control and safety devices.

7.3 TERMINAL OF ELECTRONIC CONTROL

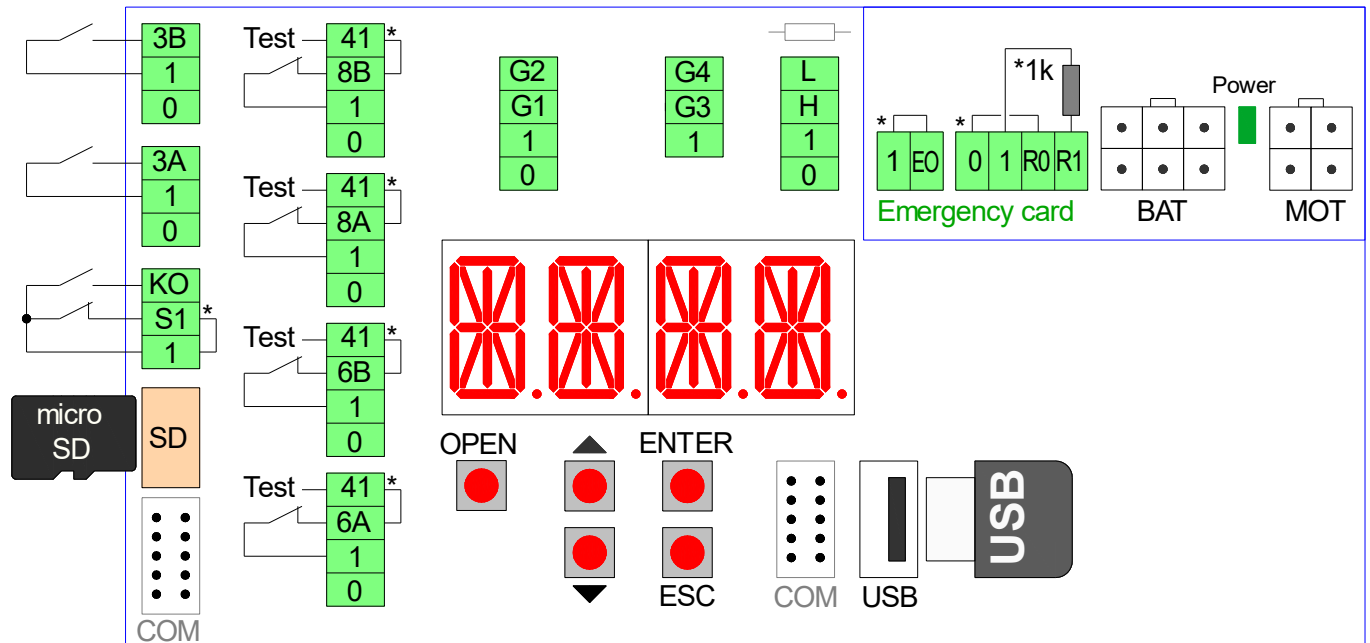

Note: The terminals with the same number are equivalent.

The electronic control comes with the jumpers on the terminals with an asterisk [*]. When connecting safety devices remove the jumpers of the corresponding terminals.

Terminals	Description
0 – 1	Output 12 Vdc for external powering accessories. The maximum absorption of 1 A corresponds to the sum of all the terminals 1 (+12V).
1 – 3A	Contact N.O. opening A side (interior side).
1 – 3B	Contact N.O. opening B side (outer side).
1 – KO	Contact N.O. open priority, connect to devices accessible only by authorized personnel with keys or codes.
1 – S1	Contact N.C. limit-switch of the locking device.
1 – 8A	Safety contact N.C. on doorway side A (interior side). When the door is closing, the opening of the contact causes the reversal of the movement. Note: connect safety devices with test (see terminal 41), and remove the jumper 41 - 8A.
1 – 8B	Safety contact N.C. on doorway side B (outer side). When the door is closing, the opening of the contact causes the reversal of the movement. Note: connect safety devices with test (see terminal 41), and remove the jumper 41 - 8A.
1 – 6A	Opening safety contact N.C. side A (left side). When the door is opening, the opening of the contact causes the slowdown of the door in the last 500 mm (the safety function of the terminal 6 can be changed using the advanced settings menu). Note: connect safety devices with test (see terminal 41), and remove the jumper 41 - 6A.
1 – 6B	Opening safety contact N.C. side B (right side). When the door is opening, the opening of the contact causes the slowdown of the door in the last 500 mm (the safety function of the terminal 6 can be changed using the advanced settings menu). Note: connect safety devices with test (see terminal 41), and remove the jumper 41 - 6A.
41	Test output (+12 V). Connect the safety devices with test (in accordance with EN 16005), as indicated in the following chapters. Note: in case of devices without test, connect the N.C. contact to terminals 41 - 8A or 41 - 8B, or 41 - 6A, or 41 - 6B.
1 – G1/G2/G3/G4	Input terminal provided for general use.
0 – G1/G2	Output terminal (12 Vdc, 30 mA max) provided for general use. Using the ADV > STG1/STG2/STG3/STG4 menu you can choose a specific function to the G1/G2/G3/G4 terminal.
0 – 1 – H – L	Bus connection to the function selector.
USB	USB standard. Allows saving the door settings and loading the firmware updates.
SD	Micro SD standard. Allows saving the door settings and loading the firmware updates.
COM	Connection for remote communication

Terminals	Description
0 – 1	Output 12 Vdc (300mA max) for external powering accessories.
R1 – R0	Current input for the opening sensor for emergency exit side A, internal view of automation (remove the jumper and the resistor of the terminals).
1 – EO	Contact N.C. of emergency opening. The opening of the contact causes the door to open (connect the emergency opening device and remove the jumper 1 – EO).
POWER	The green led indicates that the Emergency board is powered and working.

Buttons	Description
OPEN	Open the door.
↑	Scroll the menu and increase of selected values.
↓	Scroll the menu and reduction of selected values.
ENTER	Button to select the menu and save the selected data.
ESC	Exit the menu.

7.4 ELECTRICAL CONNECTION OF FUNCTION SELECTOR

Connect the 0-1-H-L terminals of the function selector, by cable (not supplied by us), to the 0-1-H-L terminals of the electronic control.

Note: for lengths over 10 m, use a cable with 2 twisted-pairs.

ATTENTION: the function selector must be used by authorized personnel only; if it is installed in a place accessible to the public, the function selector must be protected by a proximity badge (13.56MHz ISO15693 and ISO14443 Mifare) or by a numeric code (max 40 badges and codes).

The function selector allows the following settings.

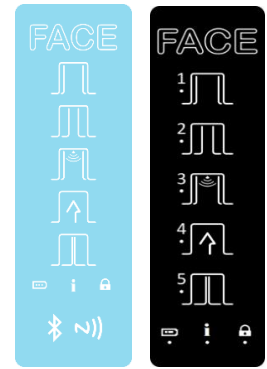

Symbol	Description
	<p>OPEN DOOR When selected, the symbol lights up, the door is permanently open. Note: the leaves can still be handled manually.</p> <p>LOW SPEED OPERATION Select the symbol for 5 seconds (double beep), the AUTOMATIC symbol flashes and the door works without safety sensors with reduced speed. Note: this mode must be used temporarily in the event of a malfunction of the safety sensors.</p>
	<p>AUTOMATIC PARTIAL OPERATION When selected, the symbol lights up and automatic operation of the door is with a partial opening of the leaves.</p>
	<p>AUTOMATIC BI-DIRECTIONAL OPERATION When selected, the symbol lights up, the door works automatic in bidirectional mode.</p> <p>RESET Select the symbol for 5 seconds, the automation performs the self-test and the automatic learning.</p>
	<p>AUTOMATIC ONE-WAY OPERATION When selected, the symbol lights up and automatic operation of the door is in one-way mode.</p>
	<p>CLOSED DOOR When selected, the door is permanently closed. If the locking device is present, the door is closed and locked. Note: using the menu SEL > DLAY you can adjust the delay time to close the door.</p> <p>CLOSING PRIORITY Select the symbol for 3 seconds, the automation closes slowly. Note: if present, the safety sensors are disabled.</p>
	<p>PROTECTED FUNCTION SELECTOR The symbol lights up if the function selector is protected. To activate the temporary operation of the function selector is necessary to approach the badge to the NFC symbol, or enter the code, or select for 3 seconds the logo.</p>
	<p>ACTIVATION OF FUNCTION SELECTOR BY LOGO (SEL>SECL=LOGO) Select the logo for 3 seconds (the lock symbol light off), the function selector is activated for 10 seconds. Expired the time the function selector switches off (the lock symbol lights up). Note: the function selector logo flashes when the CAN bus communication is not working (H-L terminals).</p>
	<p>ACTIVATION OF FUNCTION SELECTOR BY BADGE (SEL>SECL=TAG) Approach the badge to the NFC symbol (the lock symbol light off), the function selector is activated for 10 seconds. Expired the time the function selector switches off (the lock symbol lights up).</p>
1 2 3 4 5	<p>ACTIVATION OF FUNCTION SELECTOR BY NUMERIC CODE (SEL>SECL=TAG) Press the logo, enter the code (maximum 5 numbers), press the logo for confirmation, (the lock symbol light off), the function selector is activated for 10 seconds. Expired the time the function selector switches off (the lock symbol lights up).</p>
	<p>BATTERY SIGNAL Battery symbol off = the door is operating with the mains supply Battery symbol on = the door is operating with battery power Battery symbol flashing = the battery is low or disconnected</p>
	<p>INFORMATION SIGNAL Information symbol on = it is necessary to perform the ordinary maintenance of the door. Information symbol flashing = shows the presence of alarms: - 1 flash = failure of electronic control or locking device; - 2 flashes = mechanical failure; - 3 flashes = failure of sensor safety test; - 4 flashes = motor overtemperature. - 5 flashes = failure of Emergency electronic control</p>

7.5 ELECTRICAL CONNECTION OF OPENING AND SAFETY SENSOR

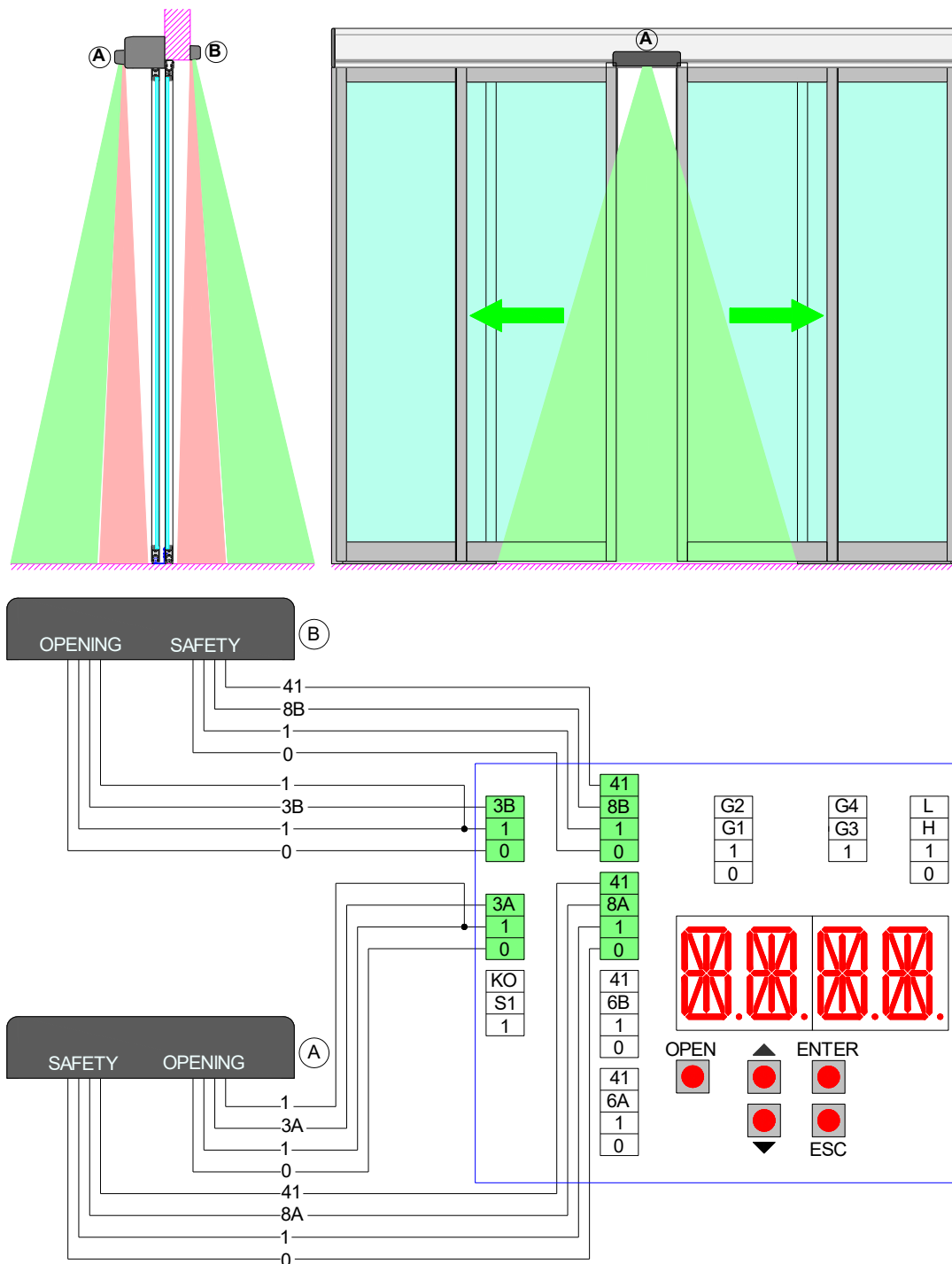

Connect the sensor, using the supplied cable, to the terminals of the electronic control, as follows:

	5CB01	OSD1 (PrimeTec B)	OSD9 (DualSense D)	OSD3 (VIO-DT1) OSD4 (IXIO-DT3)	OSD4 (IXIO-DT3 ARTEK)	OSD5 (3H-IR14C) OSD8 (SSR-3-ER)
OPENING	0	White	White	Brown	Black	Black
	1	Brown Yellow	Brown Yellow	Green Yellow	Red Yellow	Red White
	3A (3B)	Green	Green	White	Yellow	Green
SAFETY	0	Gray	Gray	Blue	Blue	Brown
	1	Red	Red	Pink	Pink	Yellow
	8A (8B)	Blue	Blue	Gray	Pink	Blue
	41	Pink	Pink	Red	Blue	Gray (OSD5: DIP8=ON)
			Purple	White / Black	Yellow / Black	Light blue
		Black	Yellow / Black	Yellow / Red	Pink	

For more information, check the installation manual of the sensor.

7.6 ELECTRICAL CONNECTION OF OPENING AND SAFETY SENSOR FOR EMERGENCY EXIT

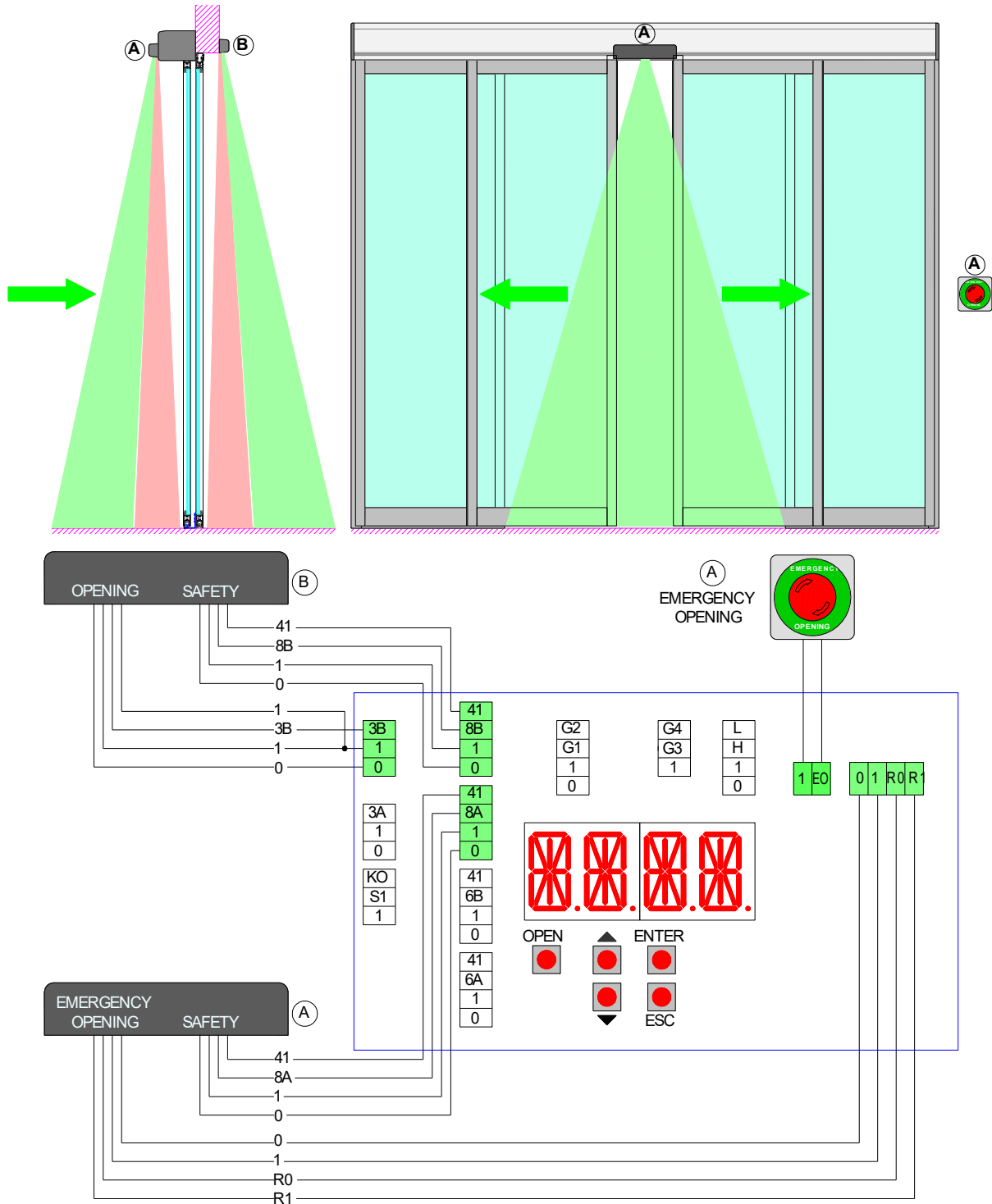

Connect the sensor A side, using the supplied cable to the terminals of the electronic control, as follows:

	5CB01E	OSD4 (IXIO-DT3) output=current	OSD4 (IXIO-DT3 ARTEK) output=current	OSD8 (SSR-3-ER) DIP3Y=ON, DIP4Y=ON	OSD9 (DualSense D)
OPENING	0	Brown	Black	Black	White
	1	Green	Red	Red	Brown
	R0	White / Black	Yellow / Black	Light blue	Purple
	R1	Yellow / Black	Yellow / Red	Pink	Black
SAFETY	0	Blue	Blue	Brown	Gray
	1	Pink	Pink	Yellow	Red
	8A	Gray	Pink	Blue	Blue
	41	Red	Blue	Gray	Pink
		Yellow	Yellow	White	Yellow
	White	Yellow	Green	Green	

Connect the sensor B side, using the supplied cable to the terminals of the electronic control as indicated in Section 7.5. For more information, check the installation manual of the sensors.

7.7 ELECTRICAL CONNECTION OF SAFETY SENSOR

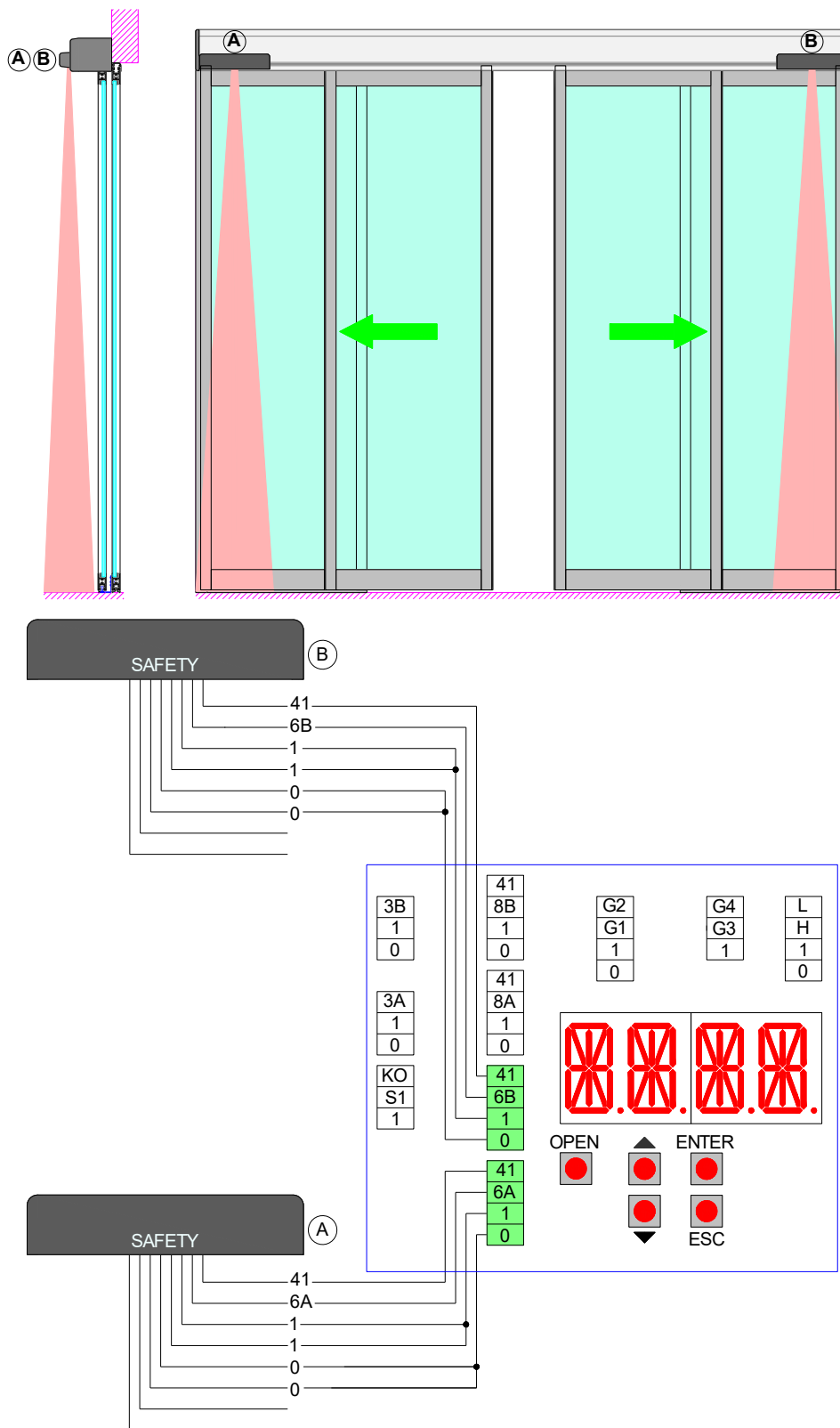

Connect the sensor, using the supplied cable to the terminals of the electronic control as follows:

	5CB01	OSD5 (3H-IR14C)	Notes
SAFETY	0	Black Brown	
	1	Red Yellow	
	6A (6B)	Blue	Remove the jumper 41-6A (6B)
	41	Gray (DIP8=ON)	
		White	Do not connect
		Green	Do not connect

For more information, check the installation manual of the sensor.

8. ELECTRONIC CONTROL ADJUSTEMENT

The electronic control has 4 buttons and 4 alphanumeric displays to set all the necessary adjustments. After turning on the electronic control, the display shows the word "MENU". The operation of the four keys are indicated in the table.

Keys	Description
ENTER	Select button, each time you press the button you enter on the selected parameter. Save button, pressing for 1 seconds you "SAVE" the selected value. There are the following menu: MENU = Main parameters menu ADV = Advanced parameters menu SEL = Function selector menu MEM = Memory management menu INFO = Information and diagnostics menu
ESC	Exit button, exit from all the parameter or exit from the menu.
↑	Scroll button, each press selects a menu item or increases the value of the selected item.
↓	Scroll button, each press selects a menu item or reduces the value of the selected item.

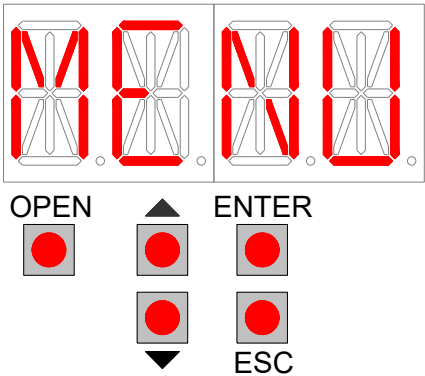

8.1 MENU (MAIN SETTINGS MENU)

Using the buttons ↑ and ↓ choose MENU, press ENTER to select and adjust the following parameters:

(*) Factory settings

Display	Description
DOOR DOOR TYPE	Setting the automation type. Choose from the following values: STD = standard for automations type: ADVANCED, EMERGENCY, HEAVY, TELESCOPIC BIG1 = for BIG automation with belt gear unit and big pulley HSTD = for HERMETIC automation HBIG = for HERMETIC-BIG automation BIG = for BIG automation (OLD VERSION)
OPEN OPENING DIRECTION	Setting the opening direction. Choose between the following values: ↔ → (*) = 2-leaves door or 1-leaf door opening to right ← = 1-leaf door opening to left. In the case of 1-leaf EMERGENCY automation with opening on the left, the carriage must be fixed to the belt at the top.
PART PARTIAL OPENING	Setting the percentage of partial opening. Choose between the minimum and maximum: minimum value = 10% maximum value = 90% (*) In case of EMERGENCY automation, the partial opening must meet the local legal requirements.
VOP OPENING SPEED	Opening speed setting. Choose between the minimum and maximum: minimum value = 100 mm/s maximum value = 800 mm/s (* 500 mm/s) If the door is heavy, the set speed is automatically reduced to allowed values (see the technical data). In case of EMERGENCY automation, set the opening speed ≥ 300 (if 2-leaves door), or ≥ 550 (if 1-leaf door).
VCL CLOSING SPEED	Closing speed setting. Choose between the minimum and maximum: minimum value = 100 mm/s maximum value = 800 mm/s (* 300 mm/s) If the door is heavy, the set speed is automatically reduced to allowed values (see the technical data).
TAC CLOSING TIME	Setting the door closing time. Choose between the minimum and maximum: NO = the door is always open minimum value = 1 s (*) maximum value = 30 s
PUSH MOTOR POWER	Force setting. Choose between the minimum and maximum: minimum value = 1 maximum value = 10 (*)

Display	Description
LEAF DOOR WEIGHT	Setting the weight of the door and the friction. Choose between the following values: NO = without door MIN = light door / little friction MED (*) = middleweight / average friction MAX = heavy door / a lot of friction HEVY = automation HEAVY version, for heavy doors
RAMP ACCELERATION	Set the acceleration time. Choose between the minimum and maximum values: SLOW = slow acceleration MED (*) = medium acceleration FAST = fast acceleration
BTMD BATTERY MODE	Setting operation of battery power device, in absence of electricity. Choose between the following values: NO (*) = battery not connected EMER = emergency open CONT = continuation of normal operation of the door Note: the number of operations with battery, depends on the efficiency of the battery, the weight of the doors and the present friction. UNLK = the locking device is released and the door remains stationary. FIRE = priority closing of the door for fire alarm. Note: If the automatic door is turned off for long periods, disconnect the battery from the electronic board.

8.2 ADV (ADVANCED PARAMETERS MENU)

Using the buttons ↑ and ↓ select ADV, press ENTER to select and adjust the following parameters.

(*) Factory settings

Display	Description
OSSM OPENING SAFETY MOTION	Setting the slowdown distance of the opening sensors (see 6A/6B terminals). Choose between the following values: NO = no slowdown 100 / 200 / 300 / 400 / 500 = the door slows down in the last 100/ 200/ 300/ 400/ 500 mm of opening YES (*) = the door slows down during the whole opening (EMERGENCY - Selection not comply to EN 16005)
OSSS OPENING SAFETY STOP	Setting the stopping distance of the opening sensors (see 6A/6B terminals). Choose between the following values: NO (*) = no stop 100 / 200 / 300 / 400 / 500 = the door stops in the last 100/ 200/ 300/ 400/ 500 mm of opening (EMERGENCY - Selections not comply to EN 16005)
TYLK LOCK TYPE	Selecting type of locking device. Choose between the following values: LK1 (*) = bistable locking device (SL5LD) LK2 = safety brake device 24Vdc 0,1÷0,4A (SL5SB1, SL5SB3, SL5SB4, SLTSB) LK3 = monostable locking device 12-24Vdc 0,2÷0,6A (SL5LD1). Not for EMERGENCY. LK4 = monostable anti-panic locking device 12-24Vdc 0,2÷0,6A (SL5LD1). Not for EMERGENCY.
ELLK LOCK OPERATION TYPE	Selecting type of lock operation. Choose between the following values: AUTO (*) = unlocked with automatic operation while locked with unidirectional operation and door closed UNLK = always unlocked with automatic operation and unidirectional. Automatic setting for EMERGENCY automation with LK1. LOCK = always locked the door closed (if TYLK=LK2, LOCK = always locked with door closed and open)
FILK LOCK OPERATION FIRE	Selection of the type of operation of the locking device in the event of a fire alarm (FIRE). Setting not available for EMERGENCY automation. ELLK = the locking device works as set in the ELLK parameter UNLK = the locking device is unlocked LOCK (*) = the locking device is locked
PUCL PUSH DOOR CLOSED	Setting the push on the closed mechanical stop. Choose between the following values: NO = no push MIN (*) = light push MED = medium push MAX = heavy push
PIPP PUSH DOOR OPEN	Setting of the opening push. Choose between the following values: NO (*) = no push YES = push enabled

Display	Description
HOLD HOLD DOOR OPEN	Setting the push of keeping the door open (TO BE USED WITH THE KSLF/KSLFT DEVICE). Choose between the following values: NO (*) = no push MIN = light push MED = medium push MAX = heavy push
PUGO PUSH & GO	Push opening activation. Choose between the following values: NO (*) = disable YES = enable
TAKO KO-CLOSING TIME	Setting the door closing time, after the 1-KO command. Choose between the minimum and maximum: NO (*) = see MENU > TAC minimum value = 1 s maximum value = 30 s
VTAC VARIABLE CLOSING TIME	Automatic closing time variable in relation of pedestrian traffic. Choose between the following values: NO = disable YES (*) = enable
MOT MOTOR CIRCUIT	Setting the manual friction of the door (only with power supply), by means of the electrical connection of the motor windings. Choose between the following values: OC (*) = manual door opening without friction (motor with open circuit windings) SC = manual door opening with friction (motor with short-circuit windings)
T41 SAFETY TEST	Enable test for safety devices (in accordance with EN 16005). Choose between the following values: NO = test disabled (NOT COMPLY TO EN 16005) YES (*) = test enable
EMER EMERGENCY DOOR	For EMERGENCY automation only. If necessary, you can turn off the operation as an emergency exit. Choose between the following values: NO = emergency exit disabled (not comply to EN 16005) YES (*) = emergency exit enabled MAX = emergency exit enabled (for doors with high friction)
PULY MOTOR PULLEY	Set the type of motor pulley. Choose between the following values: 15 (*) = WHITE motor pulley with 15 teeth 18 = BLACK motor pulley with 18 teeth (old version)
SYNC DOOR SYNCHRO- NIZATION	Two single-leaf automations with synchronized movement. Choose between the following values. NO (*) = no synchronism MST1 = automazione MASTER automation SLV1 = automazione SLAVE automation MST2 = MASTER external automation (see menu: ADV > INK > EXT) SLV2 = SLAVE external automation (see menu: ADV > INK > EXT)
INK INTER-LOCKED DOOR	Interlocked operation of two automatic doors, the opening of a door is permitted only when the other door is closed. Choose between the following values. (EMERGENCY - Selection not comply to EN 16005) NO (*) = no interlock INT = internal door EXT = external door
ID ID NUMBER	If several automations are connected to the network via the 1-H-L terminals, they must have different identification numbers. Choose between the following values: NO (*) = no network 0 / 1 / 2 / 3 / 4 / 5 / 6 / 7 / 8 / 9 / 10 / 11 / 12 / 13 / 14 (EMERGENCY: 0 / 1 / 2 / 3) N.B. After changing the ID, turn the automation off and on again.
PC CLOSING PUSH	Independent setting of the closing force. Choose between the following values: NO (*) = see MENU > PUSH (same force in opening and closing) minimum value = 1 maximum value = 10 Note: if necessary, the closing force (PC) can be set differently from the opening force (PUSH).

Display	Description
	INPUT COMMANDS BETWEEN 1-G1, 1-G2, 1-G3, 1-G4 TERMINALS
STG1	NO (* STG1 / STG2 / STG3) = no function
STG2	STOP = Stop contact N.C. The opening of the contact stops the door. Setting not available for EMERGENCY automation.)
STG3	FIRE = Priority closing command (N.C.), for fire alarm. Setting not available for EMERGENCY automation.
STG4	STEP = Step-by-step contact N.O. The closing of the contact performs in sequence the opening (disabled automatic closure) and the closing of the door. Note: do not use the STEP command with synchronized doors (see ADV > SYNC menu).
<i>Setting of G1, G2, G3, G4 input</i>	SAM = Automatic setting command of function selector. The closing and the opening of the contact changes the function selector mode (see menu settings: SEL > SAM1 and SEL > SAM2).
	EMER = Emergency opening contact N.C. The opening of the contact opens the door.
	PART = Partial opening contact N.O. (see menu: MENU > PART > 10-90).
	CAB = Step-by-step contact N.O. The closing of the contact performs in sequence the closing of the door (disabling 3A/3B terminals, enabling the signaling for occupied cabin) and the opening of the door (enabling 3A/3B terminals, disabling the signaling for occupied cabin). (EMERGENCY - Selection not comply to EN 16005)
	INKE = Interlocked operation exclusion command between two doors (see menu: ADV > INK)
	RSET = Reset command
	KC (* STG4) = Priority closing command (N.O.)
	SUL = Command to unlock the function selector for 10 seconds
	OUTPUT SIGNALS BETWEEN 0-G1, 0-G2 TERMINALS (12Vdc 30mA)
STG1	NO (*) = no function
STG2	BELL = The output is activated for 3 seconds when people enter the store (through the sequential activation of the safety contacts: 1-8B and 1-8A).
<i>Setting of G1, G2 output</i>	SERV = The output is activated when the door reaches the number of maintenance cycles, set using the menu: INFO> SERV.
	WARN = The output is activated when at least one warning remains active for 5 minutes. For remove the alarm signal make a reset or turn off the power supply.
	CLOS = The output is activated when the door is closed
	OPEN = The output is activated when the door is open
	LOCK = The output is activated when the door is closed and locked
	AIR = The output is activated when the door is not closed
	LAMP = The output is activated when the door is moving
	CABS = Signaling of the occupied cabin (see menu: ADV > STG1 > CAB)
	INK = Red traffic light signaling for interlocked doors (see menu: ADV > INK)
	PWOF = The output is activated in the absence of power supply (W128)
	HAND = The output is activated when the door is opened by hand
	FS = The output is activated when the door is not closed, in the presence of a fire alarm.
	3AS = The output is activated when input 3A is not active
	3BS = The output is activated when input 3B is not active
	SRES = The output is activated when a reset is performed (W127)
	EMTS = The output is activated while performing the emergency opening test every 24 hours. (for EMERGENCY only).

(*) Factory settings. ATTENTION: terminals G1, G2, G3, G4 cannot have the same settings.

8.3 SEL (FUNCTION SELECTOR MENU)

Using the buttons ↑ and ↓ select SEL, press ENTER to select and adjust the following parameters.

(*) Factory settings

Display	Description
MODE SELECTOR MODE	<p>Displaying of operating mode of function selector device. Choose between the following values:</p> <p>NO (*) = no mode</p> <p>OPEN = open door</p> <p>AUTO = automatic bi-directional operation</p> <p>CLOS = closed door</p> <p>1D = automatic one-way operation</p> <p>PA = automatic partial operation</p> <p>1DPA = automatic one-way operation and partial</p>
SECL SELECTOR LOCK	<p>How to activate the function selector. Choose between the following values:</p> <p>NO (*) = function selector always accessible</p> <p>LOGO = function selector accessible by selecting the logo for 3 seconds</p> <p>TAG = function selector accessible with badge and numeric code</p>
DLAY DELAY CLOSED DOOR	<p>Setting delay time function closed door. Choose between the minimum and maximum values:</p> <p>minimum value = 1 s (*)</p> <p>maximum value = 5 min</p>
TMEM TAG MEMORISE	<p>Saving procedure of badge and numeric code for function selector. Choose between the following values.</p> <p>NO (*) = no saving</p> <p>SMOD = Saving badge and numeric code for activation of the function selector.</p> <p>OPEN = Saving badge and numeric code for activation of priority opening: proceed as SMOD</p> <ul style="list-style-type: none"> - press the ENTER button for 1 second, the display shows REDY, FSD5 - approach the badge to the function selector (in front of the NFC symbol), the display shows the badge code, FSD6 - press the logo, enter the code (from 1 to 5 numbers), press the logo for confirmation, the display shows the numeric code (Note: the numeric code can be stored only if SECL=TAG), - wait for 2 minutes or press the ESC button. <p>Note: if the badge and the numeric code is not recognized the display shows the message UNKN.</p> <p>You can store a total maximum of 40 badges and numeric codes.</p> <p>APP = Saving phone for activation of the FACE PRC and FACE URC App</p> <ul style="list-style-type: none"> - press the ENTER button for 1 second, the display shows REDY, FSD5 – stay with the phone near the function selector (in the Bluetooth range). - wait for 2 minutes or press the ESC button.
TMAS TAG MASTER	<p>It is possible to create master badge and master numeric code that allows the saving of the badges and the numeric codes, without the use of the menu. Choose from the following values.</p> <p>NO (*) = no saving</p> <p>MMOD = creation of the master badge and master numeric code to saving badges and numeric codes for function selector activation: proceed as SMOD.</p> <p>MOPE = creation of the master badge and master numeric code to saving the badges and numeric codes of opening priority: proceed as OPEN.</p> <p>Note: if the badge and the numeric code is not recognized the display shows the message UNKN.</p> <p>FSD5 - The use of the master badge is the following:</p> <ul style="list-style-type: none"> - approach the master badge to the function selector (in front of the NFC symbol), the buzzer emits 2 beeps at the beginning of the storage procedure, - approach the badges, that you want to store, one at a time, to the function selector (in front of the NFC symbol), the buzzer emits 1 beep of confirmation storage, - wait for 2 minutes, the buzzer emits 2 beeps at the end of the storage procedure. <p>FSD6 - The use of the master numeric code is the following:</p> <ul style="list-style-type: none"> - press the logo, enter the master numeric code, press the logo for confirmation, the buzzer emits 2 beeps at the beginning of the storage procedure, - press the logo, enter the new code (from 1 to 5 numbers), press the logo for confirmation, the buzzer emits 1 beep of confirmation storage, - wait for 2 minutes, the buzzer emits 2 beeps at the end of the storage procedure. <p>Note: if the badge and the numeric code is not stored, the buzzer emits no beeps.</p>

Display	Description
TDEL TAG DELETE	<p>Cancellation procedure of badge and numeric code. Choose between the following values.</p> <p>NO (*) = no cancellation</p> <p>YES = badge and numeric code cancellation</p> <p>- press the ENTER button for 1 second, the display shows REDY,</p> <p>FSD5 - approach the badge to the function selector (in front of the NFC symbol), the display shows the badge code,</p> <p>FSD6 - press the logo, enter the code (from 1 to 5 numbers), press the logo for confirmation, the display shows the numeric code.</p> <p>- wait for 2 minutes or press the ESC button.</p> <p>Note: if the badge and the numeric code is not recognized the display shows the message UNKN.</p>
TERA TAG TOTAL ERASE	<p>How to erase all stored badges and numeric codes. Choose between the following values:</p> <p>NO (*) = no erase</p> <p>YES = cancellation of all badges and numeric codes</p>
SAM1 SELECTOR AUTOMATIC MODE	<p>First setting of function selector, when the 1-G1 / G2 / G3 / G4 contact becomes closed. Set the menu ADV > STG1 / STG2 / STG3 / STG4 > SAM.</p> <p>Connect the contact of a clock to 1-G1 / G2 / G3 / G4 terminals, and choose between the following values:</p> <p>OPEN = open door</p> <p>AUTO = automatic bi-directional operation</p> <p>CLOS (*) = closed door. In case of EMERGENCY automation, the "closed door" setting must be made only by the function selector.</p> <p>1D = automatic one-way operation</p> <p>PA = automatic partial operation</p> <p>1DPA = automatic one-way operation and partial</p>
SAM2 SELECTOR AUTOMATIC MODE	<p>Second setting of function selector, when the 1-G1 / G2 / G3 / G4 contact becomes open. Set the menu ADV > STG1 / STG2 / STG3 / STG4 > SAM.</p> <p>Connect the contact of a clock to 1-G1 / G2 / G3 / G4 terminals, and choose between the following values:</p> <p>OPEN = open door</p> <p>AUTO = automatic bi-directional operation</p> <p>CLOS (*) = closed door. In case of EMERGENCY automation, the "closed door" setting must be made only by the function selector.</p> <p>1D = automatic one-way operation</p> <p>PA = automatic partial operation</p> <p>1DPA = automatic one-way operation and partial</p>
FW FIRMWARE UPGRADE	<p>Programming procedure of function selector.</p> <p>Insert the USB/micro SD memory in the electronic control.</p> <p>From this menu, choose the firmware version you want.</p> <p>Press ENTER until it starts the programming procedure that lasts about 30 seconds, at the end the display shows "SAVE".</p> <p>After the procedure, switch the power supply off and on again. Remove the USB/micro SD memory from the electronic control and store it for future use.</p> <p>Note: in the case of programming error or missing firmware (W103), proceed as follows: disconnect the power supply, insert the USB/micro SD memory, give power supply, and repeat the programming procedure from this menu.</p>
VER VERSION	<p>Displaying the firmware version of function selector.</p>
TIN TAG INPUT	<p>You can upload the badges and numeric codes used in another automation, already stored in the USB/micro SD memory. Choose between the following values:</p> <p>NO (*) = no upload</p> <p>YES = upload the badges and numeric codes from the USB/micro SD memory</p>
TOUT TAG OUTPUT	<p>You can save the stored badges and numeric codes in the USB/micro SD memory. Choose between the following values:</p> <p>NO (*) = no save</p> <p>YES = save the stored badges and numeric codes in the USB/micro SD memory</p>
STCL CLOSED DOOR SIGNAL	<p>Set the signaling of closed and locked door, with bistable locking device and microswitch. Choose from the following values:</p> <p>NO (*) = the symbol "closed door" remains lit even if the door is opened by hand.</p> <p>YES = the symbol "closed door" lights up only when the door is really closed and locked.</p> <p>Note: if the locking device does not close the door, the symbol "closed door" flashes.</p>

8.4 MEM (MEMORY MANAGEMENT MENU)

Using the buttons ↑ and ↓ select MEM, press ENTER to select and adjust the following parameters.

(*) Factory settings

Display	Description
FSET FACTORY SETTINGS	Restore all settings to factory defaults. Choose between the following values: NO (*) = no restore. YES = restore to factory settings.
FW FIRMWARE UPGRADE	Programming procedure of electronic control. Insert the USB/micro SD memory in the electronic control. From this menu, choose the firmware version you want. Press ENTER until it starts the programming procedure that lasts about 30 seconds (or about 2 minutes for EMERGENCY automations), at the end the display shows "SAVE". After the procedure, switch the power supply off and on again. Remove the USB/micro SD memory from the electronic control and store it for future use. Note: in the case of programming error or missing firmware (W100, W104), proceed as follows: disconnect the power supply, insert the USB/micro SD memory, give power supply, the programming procedure starts automatically, or choose the firmware from this menu.
SIN SETTING INPUT	You can upload the menu settings used in another automation, already stored in the USB/micro SD memory. Choose between the following values: NO (*) = no upload YES = upload the menu settings from the USB/micro SD memory
SOUT SETTING OUTPUT	You can save the menu settings of automation in use, in the USB/micro SD memory. Choose between the following values: NO (*) = no save YES = save the menu settings of automation in the USB/micro SD memory

8.5 INFO (INFORMATION AND DIAGNOSTICS MENU)

Using the buttons ↑ and ↓ select INFO, press ENTER to select and adjust the following parameters.

(*) Factory settings

Display	Description
SHOW DISPLAY INFO	Displaying information of warning and faults. Choose between the following values: CONT (*) = the display shows the active contacts of the terminal blocks and the alarms WARN = the display shows the alarms only
VER VERSION	Displaying the firmware version of electronic control.
CYCL CYCLES	Shows the number of cycles of the door (1 = 1.000 cycles, 9000 = 9.000.000 cycles).
SERV SERVICE SIGNAL	Enabling the signaling of routine maintenance of the door. NO (*) = no signaling 1 = 1.000 cycles / 9000 = 9.000.000 cycles
LOG INFO FILE	You can save the following information in the USB/micro SD memory (sliding_log.txt): the last 20 warnings, the menu settings, and the electronic devices connected to automation. Choose between the following values: NO (*) = no save YES = save the information in the USB/micro SD memory
WARN WARNING LIST	Displaying of the last 10 warnings (the warning number 0 is the last): 0.xxx / 1.xxx / 2.xxx / 3.xxx / 4.xxx / 5.xxx / 6.xxx / 7.xxx / 8.xxx / 9.xxx

DISPLAY	SEL	FLASH	WARNING	CHECK
W001		1	Encoder error	Check encoder connection
W002		1	Motor short circuit	Check the connection of the motor
W003		1	Motor control error	Electronic control failure
W010		2	Direction reversed	Check the presence of obstacles
W011		2	Running too long	Check the connection of the belt
W012		2	Running too short	Check the presence of obstacles
W013		2	Overrun	Check the mechanical stops
W030		5	Emergency card not detected	Electronic control failure
W031		5	Communication interrupted	Electronic control failure
W032		5	Emergency sensor input failure	Electronic control failure
W033		5	Failure test of emergency opening	Check the connection motor - Emergency card

DISPLAY	SEL	FLASH	WARNING	CHECK
W034		5	Relay motor error	Electronic control failure
W035		5	Error lock position	Check the lock and microswitch connections
W036		5	Error of lock operation	Check the lock and microswitch connections
W037		5	Opening door failure	Check the presence of obstacles
W038		5	Failure test of emergency opening	Check the connection motor - electronic control
W039		5	Contact 1-KC closed more than 10 seconds	Check the connection to the terminal KC
W041		5	Error of Emergency card	Electronic control failure
W100	-	-	Programming error	Repeat the programming procedure in MEM > FW menu
W103	-	-	Programming selector error	Repeat the programming procedure in SEL > FW menu
W104	-	-	Programming Emergency error	Repeat the programming procedure in MEM > FW menu
W110		1	Internal memory error	Electronic control failure
W127	-	-	Automation reset	The automation performs a self-test
W128		on	No power supply	Check the power supply
W129		1	No battery	Check the battery connection
W130		1	Low Battery	Replace or recharge the battery
W131		1	Error of Supercapacitor	Check the connection Supercapacitor - electronic control
W140		3	6A safety test failure	Check the safety sensor connection
W141		3	6B safety test failure	Check the safety sensor connection
W142		3	8A safety test failure	Check the safety sensor connection
W143		3	8B safety test failure	Check the safety sensor connection
W145		4	Motor overtemperature (first step)	The door reduces the speed
W146		4	Motor overtemperature (second step)	The door stops
W148		1	Locking device overcurrent	Check the ADV > TYLK menu and the lock connection
W150		2	Obstacle in opening	Check the presence of obstacles
W151		2	Obstacle in closing	Check the presence of obstacles
W152		2	Door locked open	Check the presence of locks
W153		2	Door locked closed	Check the presence of locks
W160		1	Synchronization error	Check the ADV > SYNC and ADV > INK menu
W256	-	-	Power on	-
W257	-	-	Firmware update	-
W320		on	Signaling of maintenance	Check the INFO > SERV menu
W330		1	Tuning between motor and electronics	Wait about 3-30 seconds

8.6 LOW ENERGY

To reduce the force and kinetic energy of the door, make the following adjustments.

Adjust the force PUSH ≤ 5.

Adjust the opening speed (VOP) so as to open the door (90%) at the times indicated in the table.

Adjust the closing speed (VCL) so as to close the door (90%) at the times indicated in the table.

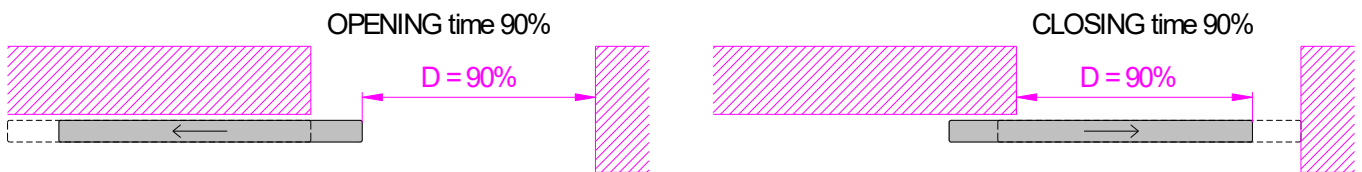

D [m]	Door weight [kg]														
	150	140	130	120	110	100	90	80	70	60	50	40	30	20	10
	Maximum speed [m/s]														
	0,15	0,16	0,16	0,17	0,18	0,18	0,19	0,21	0,22	0,24	0,26	0,29	0,34	0,41	0,58
	Time [s]														
0,7	4,7	4,6	4,4	4,2	4,0	3,9	3,7	3,5	3,2	3,0	2,7	2,5	2,1	1,8	1,3
0,8	5,4	5,2	5,0	4,8	4,6	4,4	4,2	3,9	3,7	3,4	3,1	2,8	2,4	2,0	1,4
0,9	6,0	5,8	5,6	5,4	5,2	4,9	4,7	4,4	4,1	3,8	3,5	3,1	2,7	2,2	1,6
1,0	6,7	6,5	6,3	6,0	5,8	5,5	5,2	4,9	4,6	4,3	3,9	3,5	3,0	2,5	1,8
1,1	7,4	7,1	6,9	6,6	6,3	6,0	5,7	5,4	5,1	4,7	4,3	3,8	3,3	2,7	1,9
1,2	8,0	7,8	7,5	7,2	6,9	6,6	6,2	5,9	5,5	5,1	4,7	4,2	3,6	3,0	2,1
1,3	8,7	8,4	8,1	7,8	7,5	7,1	6,8	6,4	6,0	5,5	5,0	4,5	3,9	3,2	2,3
1,4	9,4	9,1	8,7	8,4	8,0	7,7	7,3	6,9	6,4	5,9	5,4	4,9	4,2	3,5	2,5
1,5	10,0	9,7	9,4	9,0	8,6	8,2	7,8	7,3	6,9	6,4	5,8	5,2	4,5	3,7	2,6

9. START-UP PROCEDURE OF THE AUTOMATIC SLIDING DOOR (AND EMERGENCY EXIT)

9.1 Preliminary checks.

At the end of the installation, move the doors manually and make sure that operation is smooth and without friction. Check the solidity of the structure and the proper attachment of all the screws.

Check the correctness of all electrical connections.

Note: in the case of 1-leaf door for emergency exit with opening on the left, the carriage must be fixed to the belt at the upper line, as indicated in the figure.

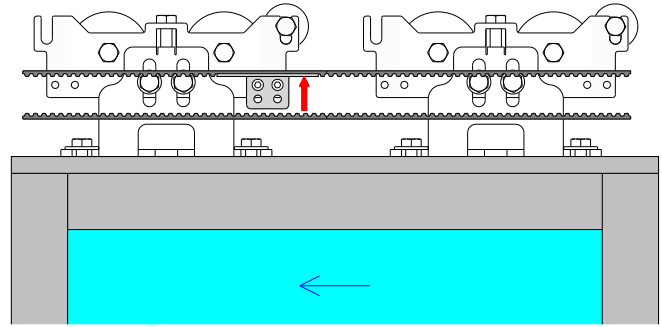

Before connecting any security devices, leave the jumper on terminals safety of electronic control (41-8A, 41-8B, 41-6A, 41-6B, 1-S1, 1-EO, 0-R0 and the resistor between 1-R1).

9.2 Giving power supply and connect the battery, if present.

Note: every time you switch on the automation performs a self-test (from 3 to 30 seconds). The first opening and closing cycle is at low speed to allow the automatic learning.

It is also performed the emergency opening test of the duration of about 10 seconds (the emergency opening test is repeated every 24 hours).

To ensure that the electronic control has the factory settings, restore via the menu:

MEM > FSET = YES (confirm by pressing ENTER for 1 second).

Select the type of automation via the menu: MENU > DOOR = STD / BIG1 / HSTD / HBIG.

If the door is 1-leaf opening to the left, set the opening direction as follows: MENU > OPEN = ← (not for EMERGENCY).

Perform the menu settings as described in Chapter 8. Use OPEN button to perform the opening door, and verify the correct operation of the door.

Note: the automation automatically detects any obstacles during the closing movement (reversal movement) and opening (stopping movement).

9.3 Connect one at a time, opening and safety devices to protect the closing cycle of the door, as described in Chapter 7.5 and 7.6, and verify proper operations.

Note: verify that the opening access is properly protected by safety sensors, in accordance with the requirements of the European standard EN16005 (annex C).

Connect one at a time, safety devices to protect the opening cycle of the door, as described in Chapter 7.7, and verify proper operations.

Note: if the gap between the door and the fixed parts meet the requirements of the European standard EN16005 (Chapter 4.6.2.1.a), the safety sensors are not needed ($X \leq 100$ mm e $Y \geq 200$ mm).

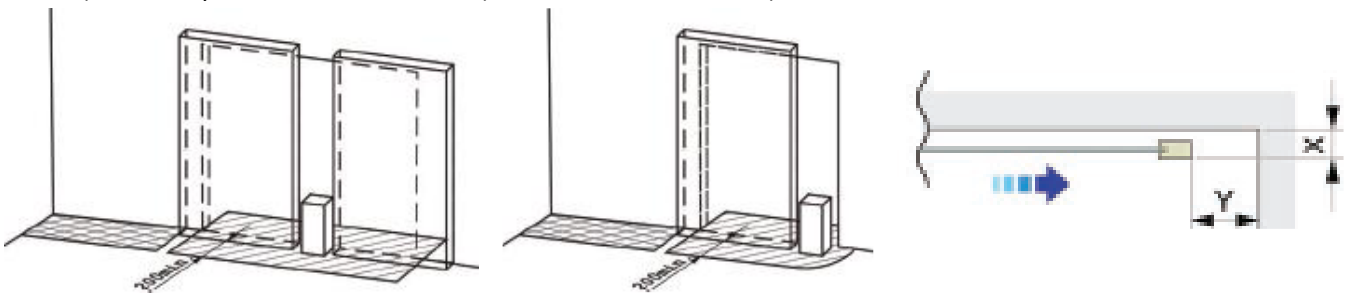

Connect the function selector device as described in chapter 7.4.

In case the locking device is installed, for EMERGENCY automations you must also install the signaling device, and connect the N.O. contact of limit switch to terminals 1-S1 of electronic control. Check the emergency opening of the door by disconnecting the power supply.

9.4 At the end of the automation starting, deliver to the owner the user instructions, including all warnings and information necessary to maintain the security and functionality of the automatic door.

The EMERGENCY automation is approved for use in emergency exits, and ensures opening of the door in all situations of: alarm, power failure, fault conditions.

Automations are feature of label on the right end cap, containing the required information by European standards EN16005 and EN60335-2-103.

Note: the manufacturer of the automatic sliding door have to add his own label identifying the installation.

FACE S.r.l.	www.facespa.it
Viale delle Industrie,74 - 31030 Dosson di Casier (TV)	
Type: SL5E	Standard: EN16005
DRIVE UNIT FOR SLIDING DOOR	
Input: 100-240V 50/60Hz Power: 70W	
Load: 150N	
Tmin: -15°C Tmax: +50°C IP20	
s/n: 1807 0001 Year: 2018	
CE	
0007818070001	

10. TROUBLESHOOTING

In addition to the following list of possible problems, there are warnings provided by the display, as described in chapter 8.5.

Problem	Possible causes	Remedy
The automation does not open or close.	No power supply (display off).	Check the power supply.
	Blow line fuse (display off).	Replace the mains fuse.
	Short circuited external accessories.	Disconnect all accessories from terminals 0-1 and reconnect them one at a time (check for voltage 12V).
	The door is locked by bolts and locks.	Check the freely move of the doors
The automation does not perform the functions set.	Function selector incorrectly set.	Check and correct the settings of the function selector.
	Control devices or safety always activated.	Disconnect devices from the terminal and verify the operation of the door.
The movement of the doors isn't linear, or reverse the movement for no reason.	The automation does not successfully perform the automatic learning.	Perform a reset using the command 1-29 , or power off and power on the automation.
The automation opens but does not close	Anomalies during the safety devices test.	Jumper contacts one at a time 41 -8A , 41 -8B , 41 - 6A, 6B - 41 .
	The opening devices are activated.	Verify that the opening sensors are not subject to vibration , do not perform false detections or the presence of moving objects in the field of action.
	The automatic closing doesn't work.	Check the settings of the function selector .
Safety devices not activating.	Incorrect connections between the safety devices and electronic control.	Check that the safety contacts of the devices are properly connected to the terminal blocks and the relative jumpers have been removed.
The automation opens by itself.	The opening and safety devices are unstable or detect moving bodies	Verify that the opening sensors are not subject to vibration , do not perform false detections or the presence of moving bodies in the field of action.
	The EMERGENCY automation is testing the emergency opening.	Wait for the test run.
	The EMERGENCY automation has detected a fault.	Check for the presence of the power supply. Check the connection of the battery and its efficiency. Check the contact closure 1-EO. Make sure that the function selector device is in protected mode (the padlock symbol should be lit). If present, check the position of the locking device and the connection 1-S1.
The locking device doesn't lock or unlock the doors.	Wrong connection of the locking device to the electronic control.	Check the correct color connection of the locking device
	The attachment lock brackets, fixed on carriage, will not release	Check the adjustment of the position of the brackets coupling lock.
	Pulling the release cord don't unlock the doors.	Check the correct fitting of the release cord on the lock.

11. AUTOMATIC SLIDING DOOR ROUTINE MAINTENANCE PLAN

To ensure proper operation and safe use of the automatic door, as required by European standard EN16005, the owner has to perform routine maintenance by qualified personnel. Except for routine cleaning of the door and any floor rails, that are under the responsibility of the owner, all maintenance and repair work must be carried out by qualified personnel. The following table lists tasks related to routine maintenance, and the frequency of intervention related to an automatic sliding door operation with standard conditions. In the case of more severe operating conditions, or in the case of sporadic use of the automatic sliding door, the frequency of maintenance can be consistently adequate.

Task	Frequency
Remove the power supply, open the automation and perform the following checks and adjustments. - Check all screws fastening of components within the automation. - Check the cleanliness of carriage and rail. - Check the correct belt tension. - Check the state of belt wear and carriage wheels (if necessary replace them). - Check the correct fitting of the doors on the carriages - If present, verify proper engagement of the locking device and the operation of the release cord.	Every 6 months or every 200.000 cycles.
Connect the power supply and perform the following checks and adjustments. - Check the correct operation of the control devices and safety. - Check the detection area of the security sensors complies with the requirements of the European standard EN16005. - If present, verify the correct operation of the locking device. - If present, verify the correct operation of the battery power device (if necessary replace the battery).	Every 6 months or every 200.000 cycles. Note: the verification of the automation security functions and safety devices must be made at least 1 time per year.

All maintenance, replacement, repair, update, etc.. must be written into the proof book, as required by European standard EN16005, and delivered to the owner of the automatic sliding door. For repairs or replacements of products, original spare parts must be used.

11.1 DISPOSAL OF PRODUCTS



The packaging materials (cardboard, plastic, and so on) should be disposed of as solid household waste, and simply separated from other waste for recycling. Our products are made of various materials. Most of these (aluminum, plastic, iron, electrical cables) are classified as solid household waste. They can be recycled by separating them before dumping at authorized city plants. Whereas other components (control boards, batteries, and so on) may contain hazardous pollutants. These must therefore be disposed of by authorized, certified professional services.

Before disposing, it is always advisable to check with the specific laws that apply in your area. **DO NOT DISPOSE IN THE ENVIRONMENT.**

DECLARATION OF INCORPORATION (FOR UK MARKET ONLY)
 The Supply of Machinery (Safety) Regulations 2008, Annex II-B



FACE S.r.l. - Viale delle Industrie, 74 - 31030 Dosson di Casier (TV) - ITALY

Declares that the Product automations for power operated pedestrian sliding door type: SL4A, SL4E, SL5A, SL5E, SL5H, SL6A, SL6E, SL6H, SL6B, SLTA, SLTE.

Has been built for installation on pedestrian door and constitutes a machine in accordance with The Supply of Machinery (Safety) Regulations 2008. The manufacturer of the power operated pedestrian door must declare its conformity in accordance with The Supply of Machinery (Safety) Regulations 2008, prior to starting-up the machine.

It complies with the applicable essential safety requirements specified in The Supply of Machinery (Safety) Regulations 2008, Annex I: 1.1.2, 1.1.3, 1.2, 1.3.1, 1.3.2, 1.3.4, 1.3.7, 1.3.8, 1.4, 1.5.1, 1.5.2, 1.5.10, 1.5.11, 1.5.14, 1.6.1, 1.6.3, 1.7

It complies with the Electromagnetic Compatibility Regulations 2016.

It complies with following harmonized standards:

EN 16005 Power operated pedestrian doorsets - Safety in use - Requirements and test methods

EN 60335-2-103 Household and similar electrical appliances - Safety - Part 2: Particular requirements for drives for gates, doors and windows

The technical documentation complies with The Supply of Machinery (Safety) Regulations 2008, Annex VII-B.

The technical documentation is managed by: Ferdinando Menuzzo with registered offices in Viale delle Industrie, 74 - 31030 Dosson di Casier (TV) - ITALY

A copy of the technical documentation shall be supplied to the competent national authorities following duly motivated request.

Place and date:
 Dosson di Casier, 2022-10-01

 Paolo Bacchin
 Managing Director